

DOUBLE DIN/STACKED ISO MOUNT UNITS RADIO PROVISION

**Note: Refer also to the instructions included with the aftermarket radio.*

- 1 Locate the factory wiring harness in the dash.

Re-connect the negative battery terminal and test the unit for proper operation.

- 2 Cut and remove the center bar from the radio housing. (Figure A)

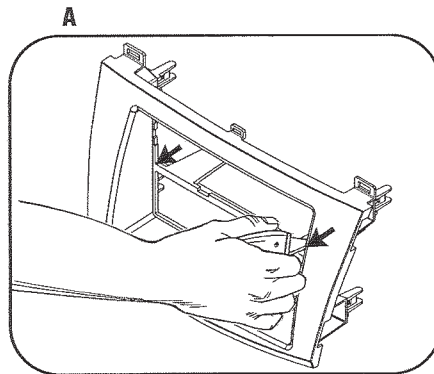

- 3 Snap the Double DIN brackets to the inside edge of the Double DIN trim plate. (Figure B)

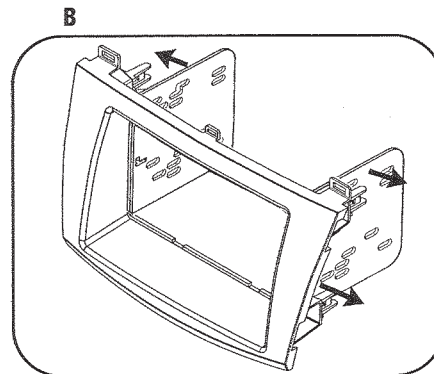

- 4 Slide the Double DIN head unit or stacked ISO head units into the bracket/radio housing assembly and secure the Double DIN head unit or stacked ISO head units to the assembly using the screws supplied with the radio. (Figure C)

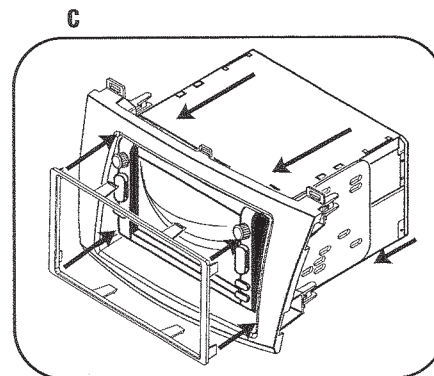

- 5 Snap the Double DIN trim plate into the Radio Housing. (Figure C)

- 6 Reassemble dash in reverse order of disassembly.



Installation Manual Double DIN Kit

Colour: black
Standard: 281170-09

• Mazda 3 2010->

Compatible with double DIN devices



Double DIN Kit contents

- (1) Facia Plate
- (2) Trim Frame
- (3) Mounting brackets

2010 MAZDA 3

- 1 Disconnect the negative battery terminal to prevent an accidental short circuit.
- 2 Unclip and remove the vent panel above the radio. (Figure A)
- 3 Remove (2) screws securing the factory radio. (Figure B)
- 4 Unclip and remove the factory radio. (Figure C)

Continued to kit assembly.

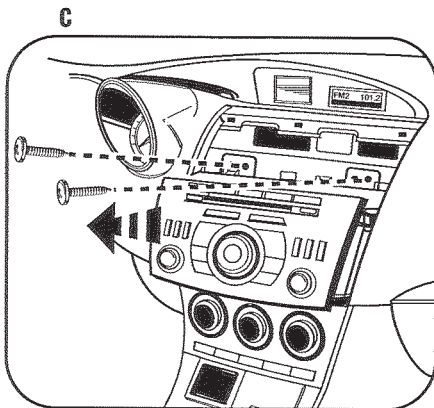
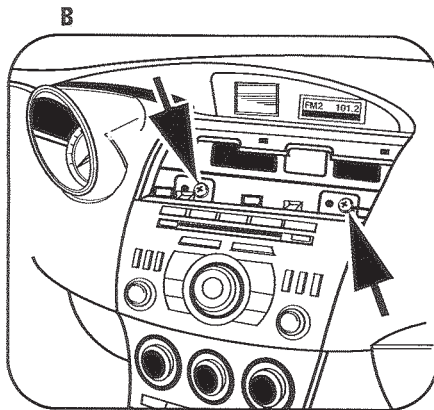
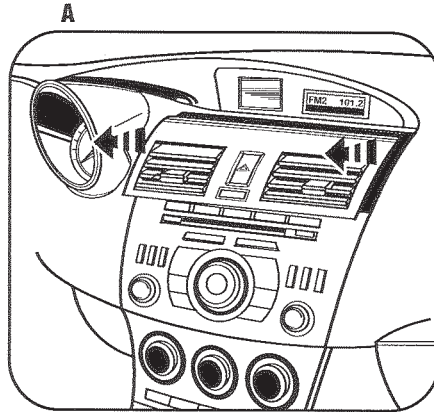

2010 MAZDA 3

- 1 Attach the radio housing brackets to the radio housing using the provided (2) Phillips screws. (Figure A,B)
- 2 Attach the panel clips to the rear of the radio housing.

Continue to kit assembly.

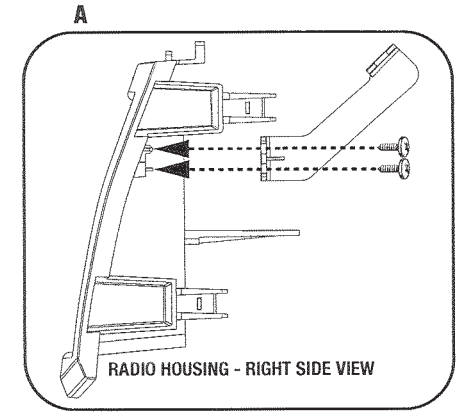

RADIO HOUSING - RIGHT SIDE VIEW

BEFORE BRACKET ASSEMBLY

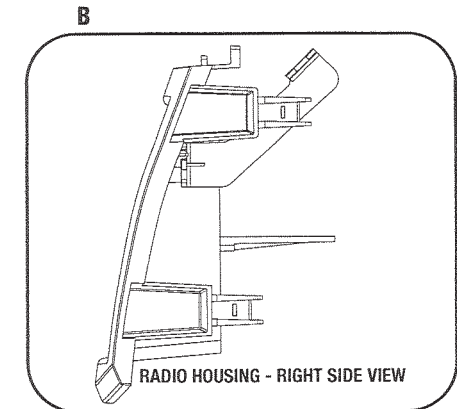

RADIO HOUSING - RIGHT SIDE VIEW

AFTER BRACKET ASSEMBLY