

since 1988

AUDIO
SYSTEM

the sound

HIGH-PERFORMANCE CAR- AMPLIFIER

OWNER'S MANUAL

H SERIES
BY AUDIO SYSTEM



H-1400.4 D
H-1600.4 D 24V



DESIGNED AND ENGINEERED BY AUDIO SYSTEM GERMANY

Congratulation on your purchase of your new **H-SERIES** amplifier.

IMPORTANT: Before installation your power amplifier, we recommend to read the owner's manual carefully and to follow the instructions regarding connection and fitting exactly.

ATTENTION: Pay attention to advices and instructions of the car manufacturer.

IMPORTANT: Your proof of purchase is evidence of warranty claim for repair or replacement. Keep your proof of purchase, manual and original packaging.

ATTENTION: Use of sound components can impair your ability to hear necessary traffic sounds and may constitute a hazard while driving your automobile.

AUDIO SYSTEMGERMANY accepts no liability for hearing loss, bodily injury or property damage as a result of use or misuse of our products. We recommend installing the equipment by an authorized service center or dealer. A professional fitting and connection is the requirement for further warranty and perfect sound.

H-1400.4 D / H-1600.4 D 24V

- 4-Channel High Power Class D amplifier
- MOS-FET PWM power supply, operating voltage from 10 to 16 V (20 to 32 V for 24V models)
- High efficiency up to 90%
- Stable into 1 Ohm per channel and 2 Ohm bridged
- Variable Lowpass-Filter from 50 to 300 Hz (Channel 1/2) and 50 to 4000 Hz (Channel 3/4)
- Variable Highpass-Filter from 50 to 4500 Hz (Channel 1/2) and 20 to 500 Hz (Channel 3/4)
- High-Level Input with Auto-Turn-On
- 2 and 4 Channel Input switchable
- Wide input sensitivity from 0,2 to 8 V
- Multi-Way-Protection-Circuitry: overheating, overcurrent, short circuit and speaker DC offset protection
- Wired remote **RTC** or **RTC PC** optional



H-1400.4 D / H-1600.4 D 24V

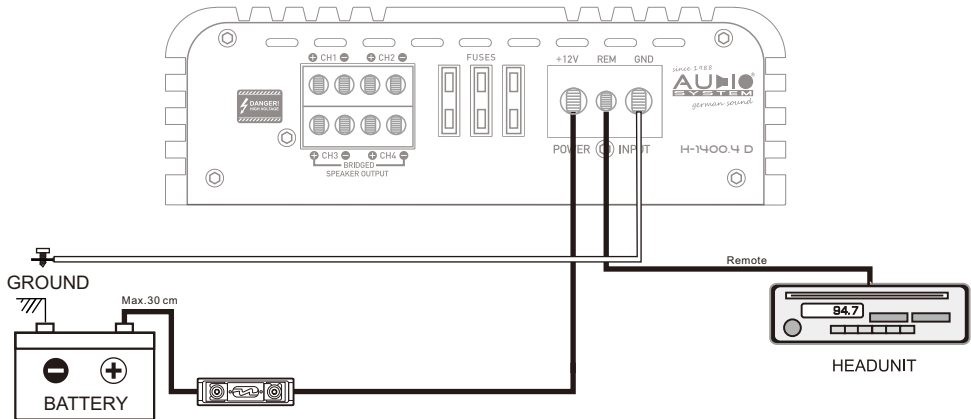

1. **Battery disconnection:** First, disconnect the power supply of the vehicle by removing the ground cable of the battery.
2. **Ground connection:** Connect the GND (ground) terminals of the amplifier with the car chassis. Keep this cable as short as possible (not longer than 50cm) and use a suitable cross section (35mm² - 50mm²). Make sure that the connection point with the chassis is free of paint, dirt and dust.
3. **+12V/+24V Power connection:** Connect the +12V/+24V terminal of the amplifier via fuse to the battery. Keep in mind, that the length of the cable from fuseholder to battery must not exceed 30cm in length. For the amplifier to work best, please use a high quality fuse holder and a suitable cable preferable 35mm² - 50mm². The fuses protect the amplifier and the vehicle against short circuits.
4. **Remote connection:** Connect the REM terminal of the amplifier to the remote output (or antenna output) of the head unit. Please use a 0.5mm² to 1.5mm² cable.

⚠ ATTENTION ⚠

Please follow the instructions during the installation of your amplifier:

- a) Take care of a professional attachment. Pay attention, that no electrical cable, gas tank, hydraulic breakers or other components get damaged.
- b) There has to be enough cooling and air circulation. Avoid the installation in small closed boxes or close to heating parts.
- c) Protect the amplifier from fluids, wetness, heat and foreign material as well as from other influences.
- d) The amplifier is only to be built into vehicles with a 12 V (24 V for 24V models) DC power supply.
- e) Never install the power supply cable with other original wires of the vehicle (gas cables), fan motors, brand control moduls etc.
- f) Install the signal cable (cinch cable) as well as the speaker cable far away from the power cables to avoid troubles with the music signal.
- g) The cables of your amplifier have to be installed, so that there is no danger of binding, squeezing or breaking.

H-1400.4 D / H-1600.4 D 24V

1. RCA connection

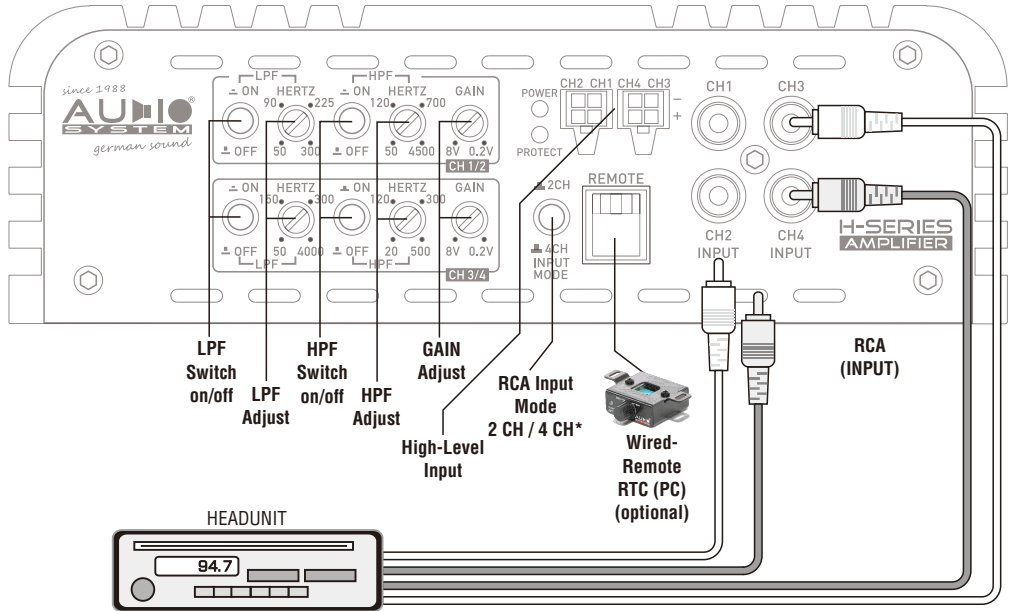

*for 2 channel input mode only connect inputs CH1/L and CH2/R

The **H-1400.4 D / H-1600.4 D 24V** amplifiers have RCA inputs, which are connected by RCA cables to the preamp outputs of the head unit. If this is not possible (usually in an original radio, OEM) the speaker outputs of the car radio can be connected directly to the High-Level inputs of the amplifier.

It is important that the gain pots are first set to minimum and turned up carefully when handling. The power stage is automatically turned on when **remote** or a **high level signal** is present.

Use the variable high pass filter (HPF) - and low-pass filter (LPF) and the gain knob to adjust the amplifier individually to your personal taste, to the characteristics of the car and to the speakers set. Also a full-active solution is possible with these amplifiers

Optionally, you can connect a wired remote **RTC / RTC PC** to control the output level of channels 3 + 4 (LP must be switched on).

AUDIO SYSTEM GERMANY, recommends that you leave your amplifier set by a specialist company, specialist dealer or a specialist to meet your needs.

H-1400.4 D / H-1600.4 D 24V

2-Channel Bridged

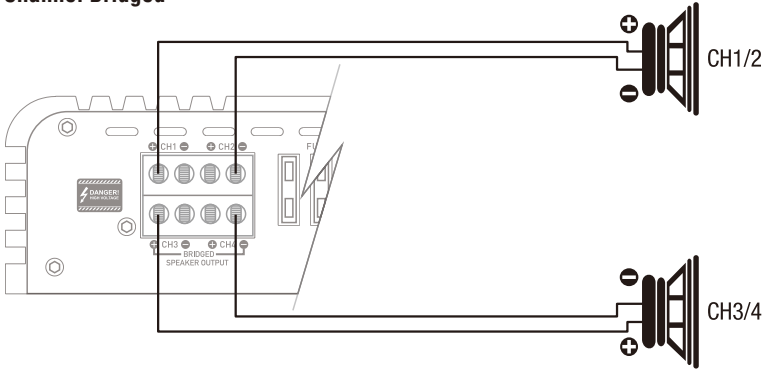

Subwoofer-
Impedance
2 ~ 8 ohm

4-Channel Stereo

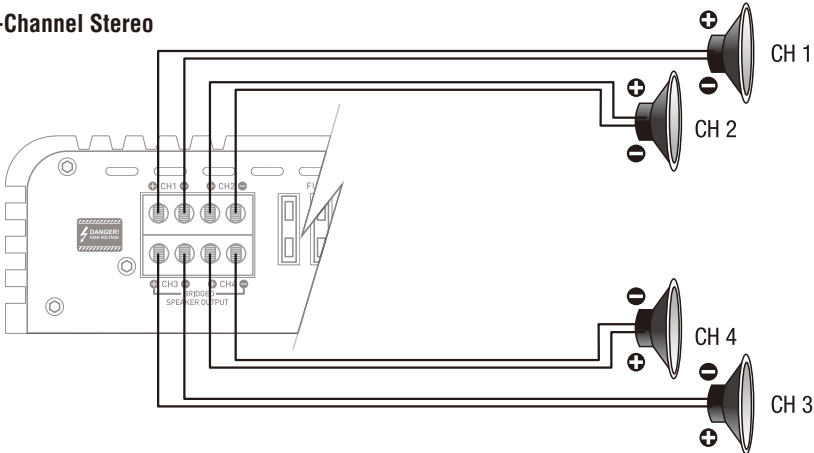

Speaker-
Impedance
1 ~ 4 ohm

2-Channel Stereo + 1-Channel Mono Bridged

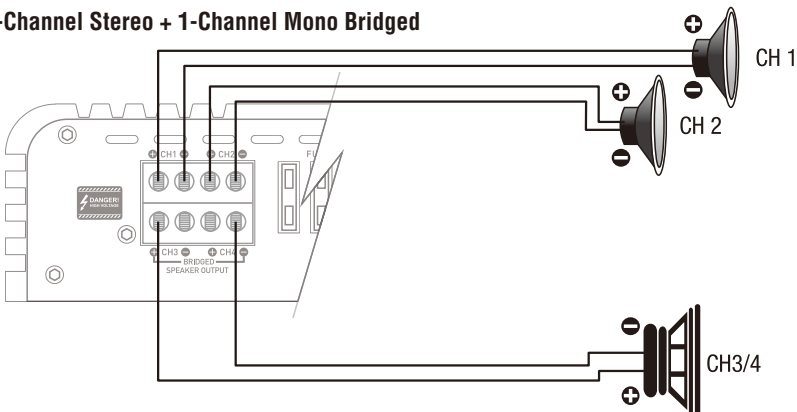

Speaker-
Impedance
1 ~ 4 ohm

Subwoofer-
Impedance
2 ~ 8 ohm

TROUBLE SHOOTING

CARBON SERIES
BY AUDIO SYSTEM

This power amplifier is featured with an efficient protection system to prevent any damages like over-heating, overvoltage, short-circuit and DC at the loudspeaker output. Occuring an error the protection-LED will light in red. In order to check the problem, first turn down all levels of the head unit, afterwards turn it off.

AMPLIFIER IS NOT POWERED UP, NO LED IS LIGHTENING	<ul style="list-style-type: none"> - ground connection professional connected? - +12V powercable professional connected? - remote cable professional connected? - fuses inserted and alright? - analyze voltage on the amplifier.
PROTECTION LED ILLUMINATES GREEN WHILE AMPLIFIER IS SOUNDLESS	<ul style="list-style-type: none"> - cinch cable alright and professional connected - loudspeaker professional connected? - head unit alright?
PROTECTION LED ILLUMINATES RED WHEN AMPLIFIER IS POWERED UP	<ul style="list-style-type: none"> - amplifier too hot? - short-circuit at the loudspeaker output? - short-circuit caused by loudspeaker cable with vehicle chassis (ground)? - input voltage too high (e.g.faulty generator)?
OVERHEATING (PROTECTION LED ILLUMINATES RED WHEN AMPLIFIER IS POWERED UP)	<ul style="list-style-type: none"> - impedance alright? - loudspeaker error? - adequate airflow of the amplifier? <p style="text-align: center;">! CAUTION ! After cooling down, the amplifier turns on automatically.</p>
ERROR IN AMPLIFIER FUSE	<ul style="list-style-type: none"> - ground professional connected? - loudspeaker impedance alright? <p style="text-align: center;">! CAUTION ! Make sure when changing fuses to use the same value.</p>
SOUND TOO LOW OR LOW-DISTORTED SOUND	<ul style="list-style-type: none"> - input level control "GAIN" is set to match the head unit? - output level control of the head unit alright? - loudspeaker error? - loudspeaker cable checked? - crossover frequencies has been properly set? (Check head unit, ampliflier, DSP, soundprozessor, equalizer, frequency bandpassfilter...)
HIGH HISS-ENGINE NOISE IN SPEAKERS	<ul style="list-style-type: none"> - ground connection professional connected? - short-circuit caused by loudspeaker cable with vehicle chassis (ground)? - cinchcable (RCA) and/or loudspeaker cable installed too close to the power connection cable? - cinch ground (RCA) of the head unit alright?

⚠ ATTENTION ⚠

Please contact your specialized dealer if the amplifier is still not working after it has been checked with the error list!

For warranty adjustment / repairs the original invoice has to be attached!
Opening the power amplifier is leading to a lost of warranty in either case!

H-1400.4 D

Power Supply Voltage	10 - 16 V
Rated Power Output at 14,4 V	
-RMS power @ 1 Ohm stereo	4x 350 W
-RMS power @ 2 Ohm stereo	4x 300 W
-RMS power @ 4 Ohm stereo	4x 200 W
-RMS power @ 2 Ohm bridged	2x 700 W
-RMS power @ 4 Ohm bridged	2x 600W
Signal to Noise Ratio	> 95 dB
Low-Pass-Filter CH1/2 CH3/4	50 - 300 Hz 50 - 4000 Hz
High-Pass-Filter CH1/2 CH3/4	50 - 4500 Hz 20 - 500 Hz
Frequency Response	10 - 20000 Hz
THD at 4 Ohm	< 0,1%
Fuse Rating	3x 50A
Input Sensitivity	200 mV ~ 8 V (+/- 5%)
Dimensions	223(W) x 59(H) x 184(L) mm

H-1600.4 D 24V

Power Supply Voltage	20 - 32 V
Rated Power Output at 14,4 V	
-RMS power @ 1 Ohm stereo	4x 400 W
-RMS power @ 2 Ohm stereo	4x 350 W
-RMS power @ 4 Ohm stereo	4x 225 W
-RMS power @ 2 Ohm bridged	2x 800 W
-RMS power @ 4 Ohm bridged	2x 700W
Signal to Noise Ratio	> 95 dB
Low-Pass-Filter CH1/2 CH3/4	50 - 300 Hz 50 - 4000 Hz
High-Pass-Filter CH1/2 CH3/4	50 - 4500 Hz 20 - 500 Hz
Frequency Response	10 - 20000 Hz
THD at 4 Ohm	< 0,1%
Fuse Rating	3x 25A
Input Sensitivity	200 mV ~ 8 V (+/- 5%)
Dimensions	223(W) x 59(H) x 184(L) mm

H-1400.4 D / H-1600.4 D 24V (SIDE VIEWS)

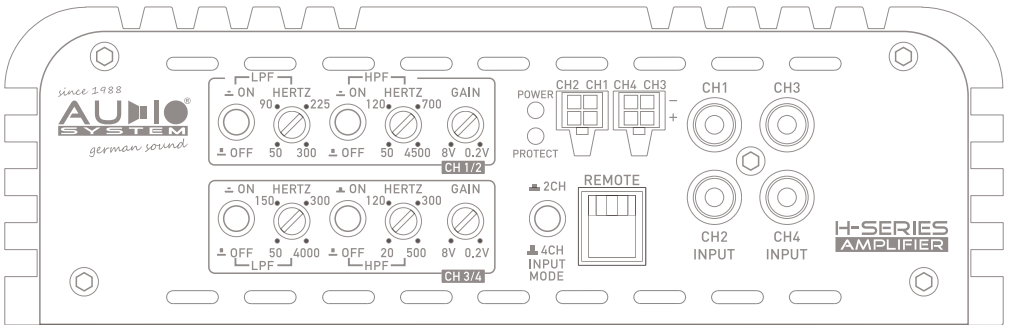
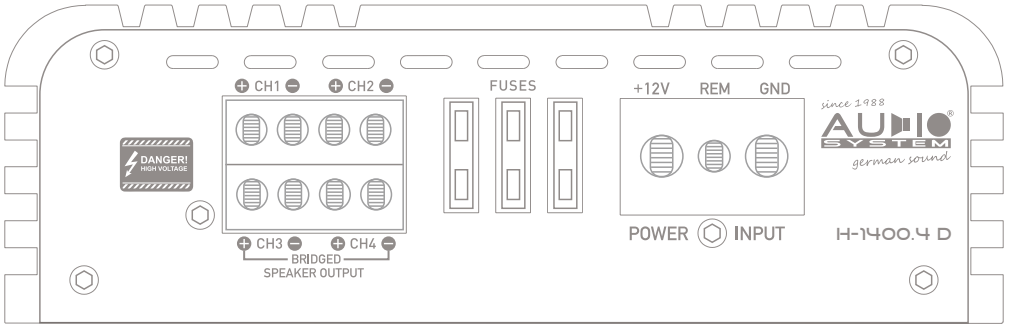

since 1988
AUDIO SYSTEM
german sound

AUDIO SYSTEM GERMANY
 FALLTORSTRASSE 6 - 76707 HAMBRÜCKEN