

KICKER®

Owner's Manual
Manual del Propietario
Manuel d'utilisatio
Benutzerhandbuch

L7X-Series Subwoofers

select language

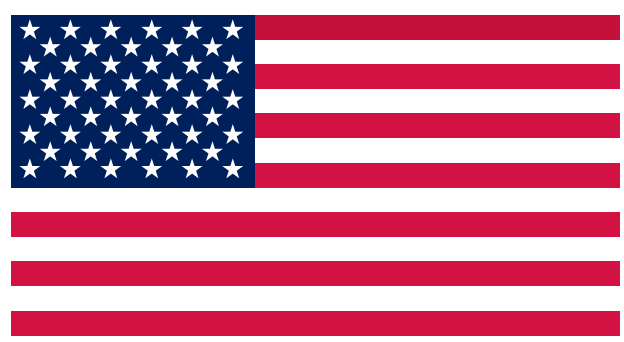

*seleccione
el idioma*

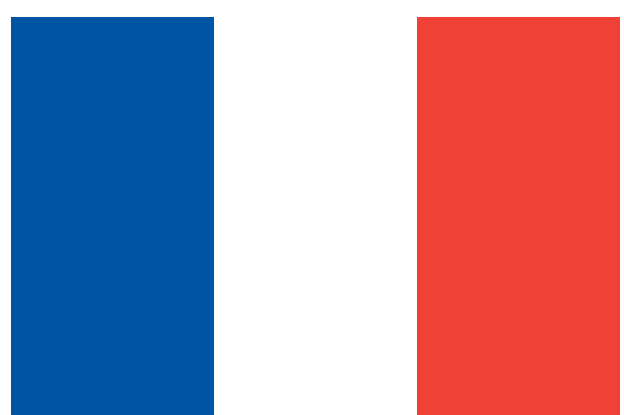

*choisir la
langue*



*sprache
auswählen*

Contents

Overview	3
Specifications	4
Installation	5
Wiring Configuration.....	5
Box Building Notes	7
Vented Enclosures.....	10
Re-Cone Kit	11
L7X8 Re-cone.....	11
L7X10–L7X18 Re-cone	24
Warranty	36
International Warranty..	101

Overview

IMPORTANT SAFETY WARNING

PROLONGED CONTINUOUS OPERATION OF AN AMPLIFIER, SPEAKER, OR SUBWOOFER IN A DISTORTED, CLIPPED OR OVER-POWERED MANNER CAN CAUSE YOUR AUDIO SYSTEM TO OVERHEAT, POSSIBLY CATCHING FIRE AND RESULTING IN SERIOUS DAMAGE TO YOUR COMPONENTS AND/OR VEHICLE. AMPLIFIERS REQUIRE UP TO 4 INCHES (10CM) OPEN VENTILATION. SUBWOOFERS SHOULD BE MOUNTED WITH AT LEAST 2 INCHES (5CM) CLEARANCE BETWEEN THE FRONT OF THE SPEAKER AND ANY SURFACE. KICKER PRODUCTS ARE CAPABLE OF PRODUCING SOUND LEVELS THAT CAN PERMANENTLY DAMAGE YOUR HEARING! TURNING UP A SYSTEM TO A LEVEL THAT HAS AUDIBLE DISTORTION IS MORE DAMAGING TO YOUR EARS THAN LISTENING TO AN UNDISTORTED SYSTEM AT THE SAME VOLUME LEVEL. THE THRESHOLD OF PAIN IS ALWAYS AN INDICATOR THAT THE SOUND LEVEL IS TOO LOUD AND MAY PERMANENTLY DAMAGE YOUR HEARING. PLEASE USE COMMON SENSE WHEN CONTROLLING VOLUME.

The L7X reimagines the massive power-handling and motor of KICKER's legendary line of L7 SoloX subwoofers with the most up-to-date engineering, materials, and design concepts. If you want the absolute best in SPL-performance and rock-bottom bass, then look no further than KICKER's award-winning pedigree with this celebrated line of subs. And remember that the driver is only half the equation. Without the immense power needed to push these subwoofers, you're short changing yourself. Use these subs with our high-powered Warhorse amplifiers to crush the competition and get all the low frequency output you're looking for!

Specifications

	L7X8	L7X10
Woofer [in, cm]	8, 20	10, 25
Recommended Amplifier Power [Watts RMS]	400–800	1000–2000
Frequency Response [Hz]	30–100	25–100
Magnet Diameter [in, cm]	6-7/8, 17.5	8 11/16, 22
Total Magnet Weight [oz, kg]	225, 6.4	406, 11.5
Voice Coil Diameter [in, mm]	2.5, 63.5	3, 75
Voice Coil Winding Width [in, mm]	1-7/8, 48	2.5, 62.5
Top Plate Thickness [in, mm]	5/16, 8	.5, 12
Rated Impedance [Ω]	1 or 2	1 or 2
Xmax (Linear Excursion) [mm]	15/16, 24	1.25, 31.25
Mounting Cutout [in, cm]	7-5/16, 18.6	9-5/16, 23.7
Mounting Depth [in, cm]	7-15/16, 20.1	9-7/16, 24

	L7X12	L7X15
Woofer [in, cm]	12, 30	15, 38
Recommended Amplifier Power [Watts RMS]	1000–2000	1000–2000
Frequency Response [Hz]	20–100	20–100
Magnet Diameter [in, cm]	8 11/16, 22	8 11/16, 22
Total Magnet Weight [oz, kg]	406, 11.5	406, 11.5
Voice Coil Diameter [in, mm]	3, 75	3, 75
Voice Coil Winding Width [in, mm]	2.5, 62.5	2.5, 62.5
Top Plate Thickness [in, mm]	.5, 12	.5, 12
Rated Impedance [Ω]	1 or 2	1 or 2
Xmax (Linear Excursion) [mm]	1.25, 31.25	1.25, 31.25
Mounting Cutout [in, cm]	11-1/16, 28.1	13-3/4, 34.9
Mounting Depth [in, cm]	10-1/8, 25.7	11-9/16, 29.3

	L7X18
Woofer [in, cm]	18, 46
Recommended Amplifier Power [Watts RMS]	1000–2000
Frequency Response [Hz]	18–100
Magnet Diameter [in, cm]	8 11/16, 22
Total Magnet Weight [oz, kg]	406, 11.5
Voice Coil Diameter [in, mm]	3, 75
Voice Coil Winding Width [in, mm]	2.5, 62.5
Top Plate Thickness [in, mm]	.5, 12
Rated Impedance [Ω]	1 or 2
Xmax (Linear Excursion) [mm]	1.25, 31.25
Mounting Cutout [in, cm]	16.5, 42
Mounting Depth [in, cm]	13-3/16, 33.5

Note: All specifications and performance figures are subject to change. Please visit www.kicker.com for the most current information. To get the best performance from your new KICKER speakers, we recommend using genuine KICKER accessories and wiring. Please allow two weeks of break-in time for the speakers to reach optimum performance.

Installation

Wiring Configuration

L7X-Series subwoofers are made with dual 1Ω or 2Ω voice coils. Both coils must be connected to a source of amplification. The Dual 1Ω will provide a 0.5Ω load wired in parallel or 2Ω load wired in series. The Dual 2Ω will provide a 1Ω load wired in parallel or 4Ω load wired in series. **Make sure your source unit or amplifier is rated at the correct ohm load for operation.**

The subwoofer wire should be kept away from sharp edges and avoid the possibility of getting pinched by the trunk. If a factory hole and grommet do not exist or are inaccessible, you must drill a hole through which to run the wire. Be careful not to drill into other wiring or existing mechanisms. Any time a wire is run through a hole, it is necessary to insert a rubber or plastic grommet to protect the wire from damage.

Pro Tip: You're a KICKER amplifier and a few cables away from a full system upgrade that will dominate any factory system! KICKER line of amplifiers make it easy to upgrade to solid bass with your existing or stock source unit. Also, ask your dealer about KICKER Speaker upgrades.

Series Wiring

Dual 1Ω Voice Coils = 2Ω Load

Dual 2Ω Voice Coils = 4Ω Load

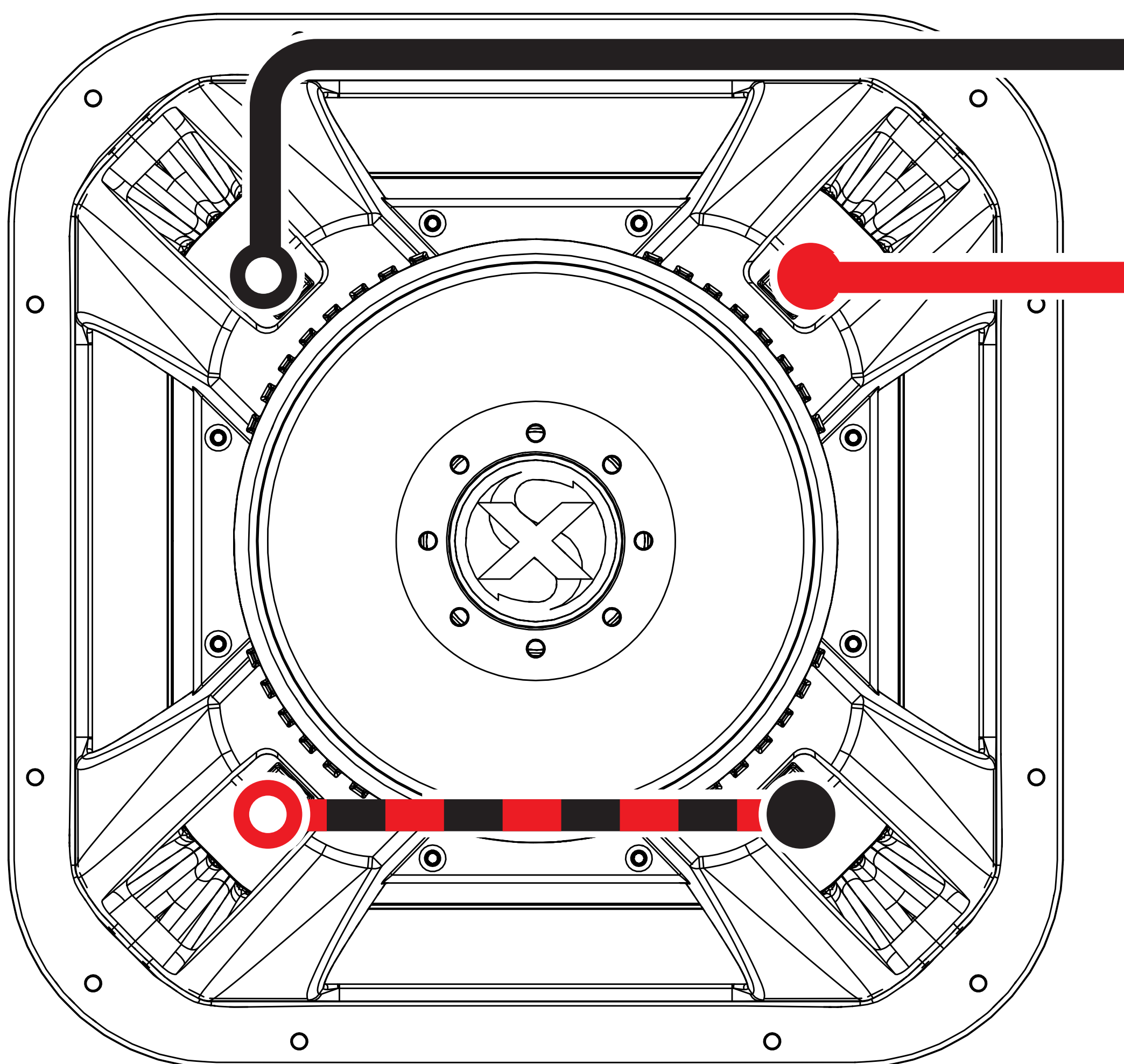

Parallel Wiring

Dual 1Ω Voice Coils = 0.5Ω Load

Dual 2Ω Voice Coils = 1Ω Load

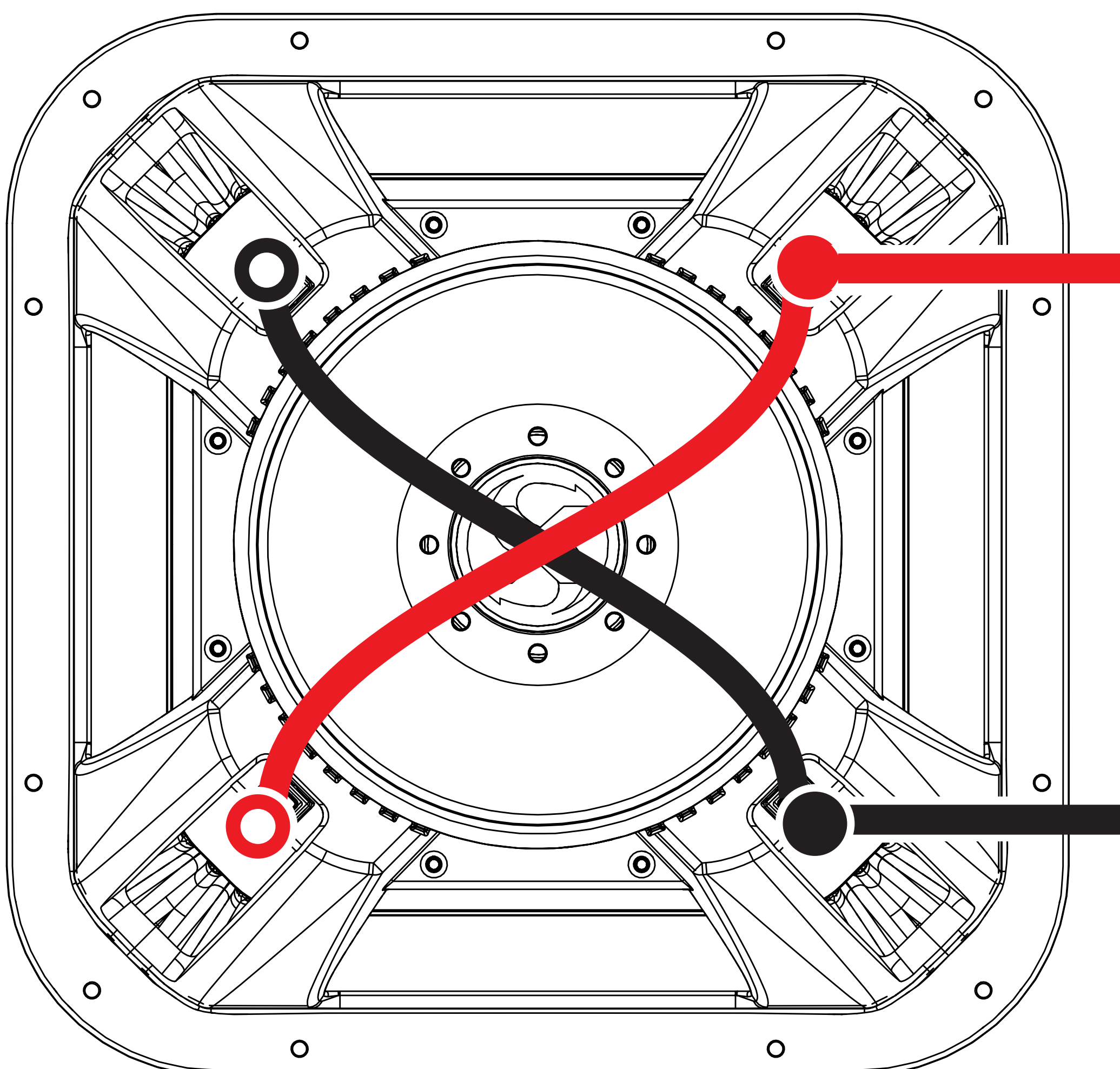

Box Building Notes

KICKER recommends using M5 or #10 mounting screws with t-nuts. Use 3/4" (1.9cm) or thicker MDF (medium density fiberboard) or birch plywood and seal the joints with silicone. Use the "template" inside your L7X subwoofer's shipping carton to mark the mounting hole, then cut directly on the line. These designs need internal bracing. Add triangular bracing between each of the larger unsupported panels.

For vented enclosures the displacement of the port must be calculated and added to the internal volume of the final design. Use the outer dimensions of the port and multiply "X x Y x Z", convert to cubic feet.

Due to the necessary length of these ports, you may want to fold the port along the bottom and back walls. It will be impractical to use round ports for these designs.

Do not install a port opening against a solid surface, such as an internal brace, back-panel or trunk wall, seat or interior panel of your vehicle. The port opening must remain unobstructed. Use the smallest dimension of the rectangular port as the minimum amount of space between the port opening and any solid surface to ensure unrestricted airflow.

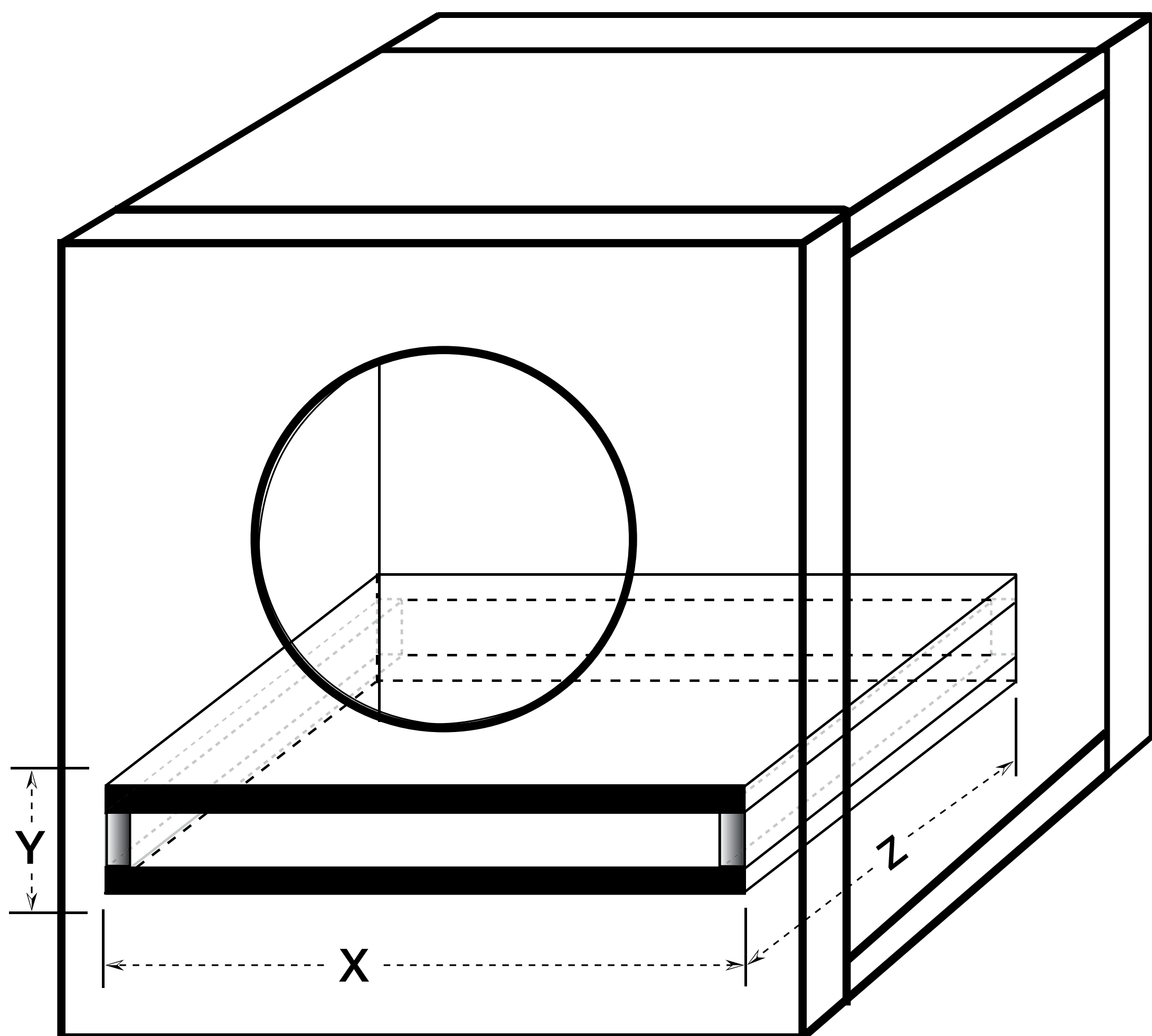

You can loosely fill your enclosure with poly-fil stuffing. Ported designs will require covering the end of the port (located inside the box) with grill cloth, chicken wire, or expanded metal to prevent the poly-fil from exiting the port. The use of poly-fil will slightly decrease efficiency, but will deepen and extend the low frequency output by making your subwoofer think it's in a bigger box.

Add triangular bracing between each of the larger unsupported panels. The mounting baffle should be double the 3/4" wall.

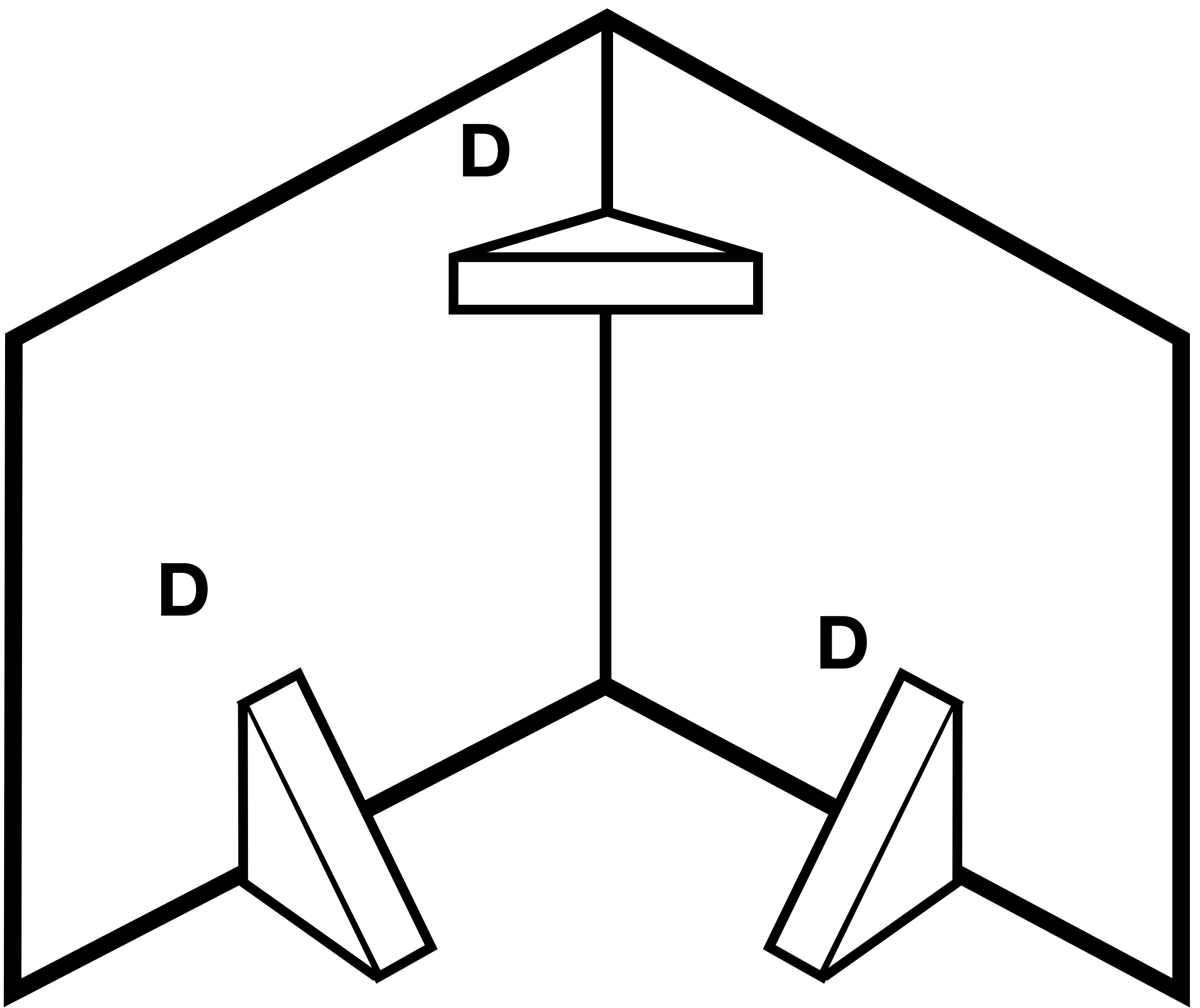

L7X12, L7X15, L7X18: D = 3" x 3" (8cm x 8cm)

L7X8, L7X10: D = 2" x 2" (5cm x 5cm)

For more advice on box building, refer to your Authorized Kicker Dealer, or click on the Support tab on the Kicker homepage, **www.kicker.com**. Please e-mail support@kicker.com or call Technical Support at (405) 624-8583 for specific or unanswered questions.

Vented Enclosures

L7X subwoofers will handle massive amounts of power. Vented enclosures increase bass efficiency and have significantly more output from 30 to 80 Hz. Output will be considerably higher than that of any sealed box. Do not forget to add the displacement of the subwoofer to the internal volume of the final design.

	L7X8	L7X10	L7X12
Recommended Vented Box Volume ft ³ [L]	.88, [25]	2, [56.6]	3, [84.9]
Port Opening, in. x in. [cm x cm]	2 X 9 [5 X 23]	2.5 X 12.25 [6 X 31]	3.5 X 13 [9 X 33]
Port Length, in. [cm]	32.25, [82]	38.5, [98]	36.5, [93]
Tuning Frequency [Hz]	39	31	31
Woofer Displacement ft ³ [L]	0.17 [4.81]	0.18 [5.09]	0.19 [5.38]

	L7X15	L7X18
Recommended Vented Box Volume ft ³ [L]	5, [141.6]	7.5, [214.5]
Port Opening, in. x in. [cm x cm]	4.25 X 16.5 [11 X 42]	6.5 X 19.5 [16.5 X 49.5]
Port Length, in. [cm]	34.75, [88]	27.75, [70.5]
Tuning Frequency [Hz]	30	28
Woofer Displacement ft ³ [L]	0.21 [5.94]	0.36 [10.19]

Re-Cone Kit

L7X8 Re-cone

The L7X8 subwoofer is a competition sub that has been engineered to be serviceable if it fails.

The L7X8RK Re-Cone Assembly consists of a pre-assembled cone, surround, and voice coil that is glued and fastened into the L7X motor and basket assembly.

Use the following steps to rebuild the L7X8.

Do not use power tools for this rebuild! The L7X magnet is extremely powerful and may cause personal injury or damage to items. Use caution around objects that contain magnetic material.

Remove the Surround Mounting Flange.

Since it is glued in place, you will need to pry it off to detach it. This may require you to break the surround mounting flange.

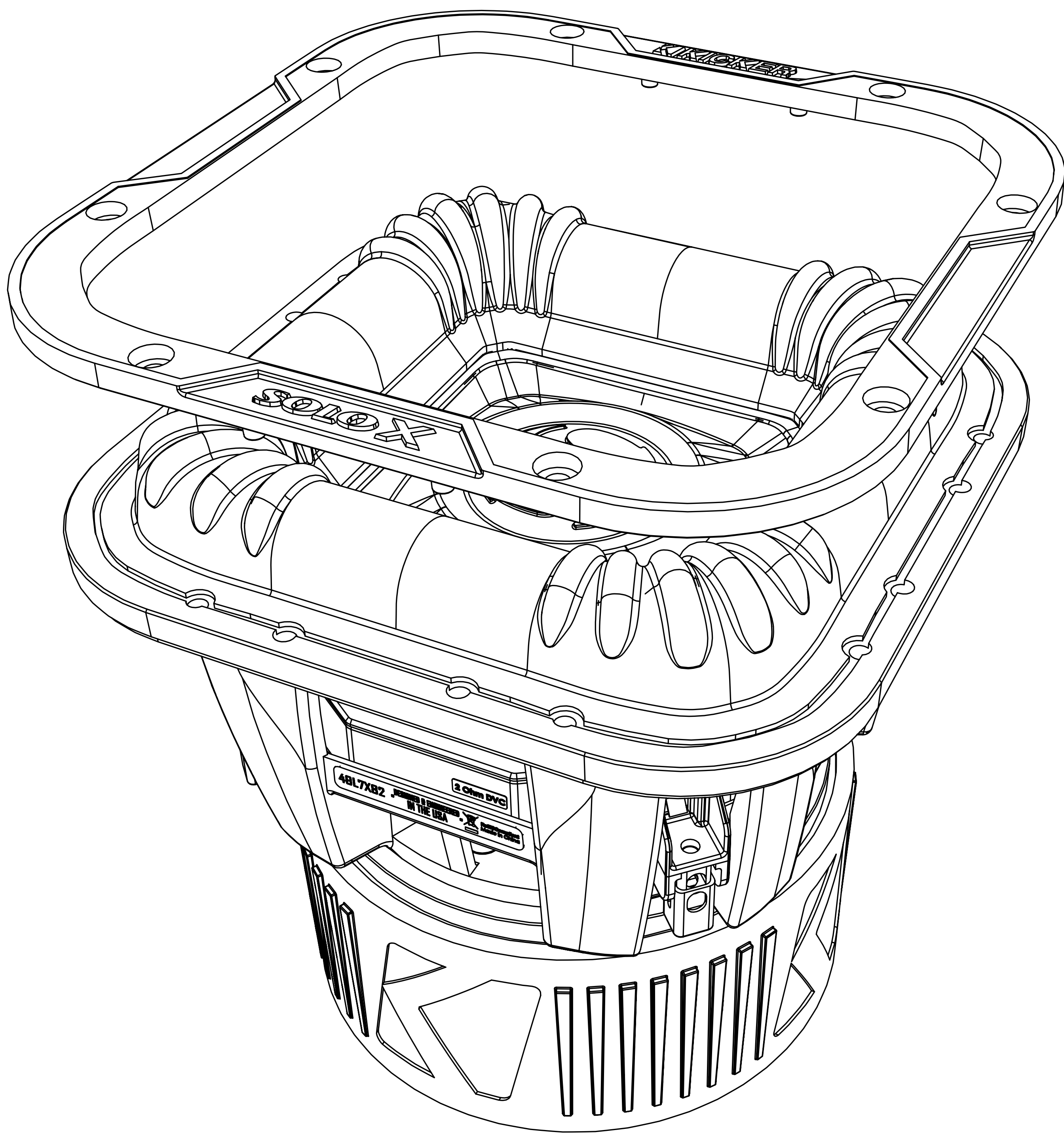

From the magnet side of the basket assembly, remove the eight M3x0.8x14mm bolts securing the spider to the basket assembly using a 2.5mm Allen wrench.

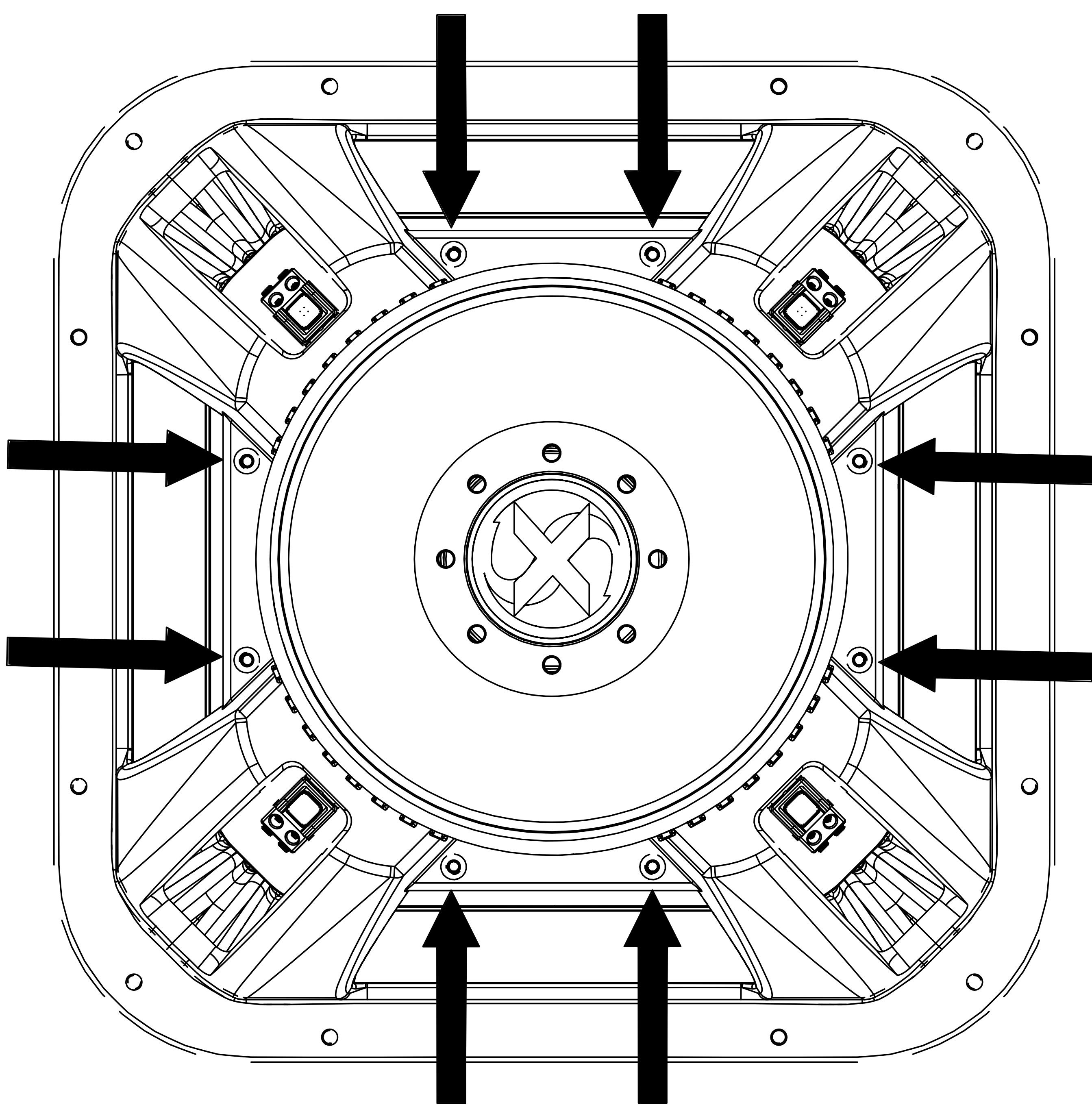

From the cone side of the basket assembly, remove the cone assembly. You will need to detach the spider landing from the basket, which could require tools such as a screwdriver or knife.

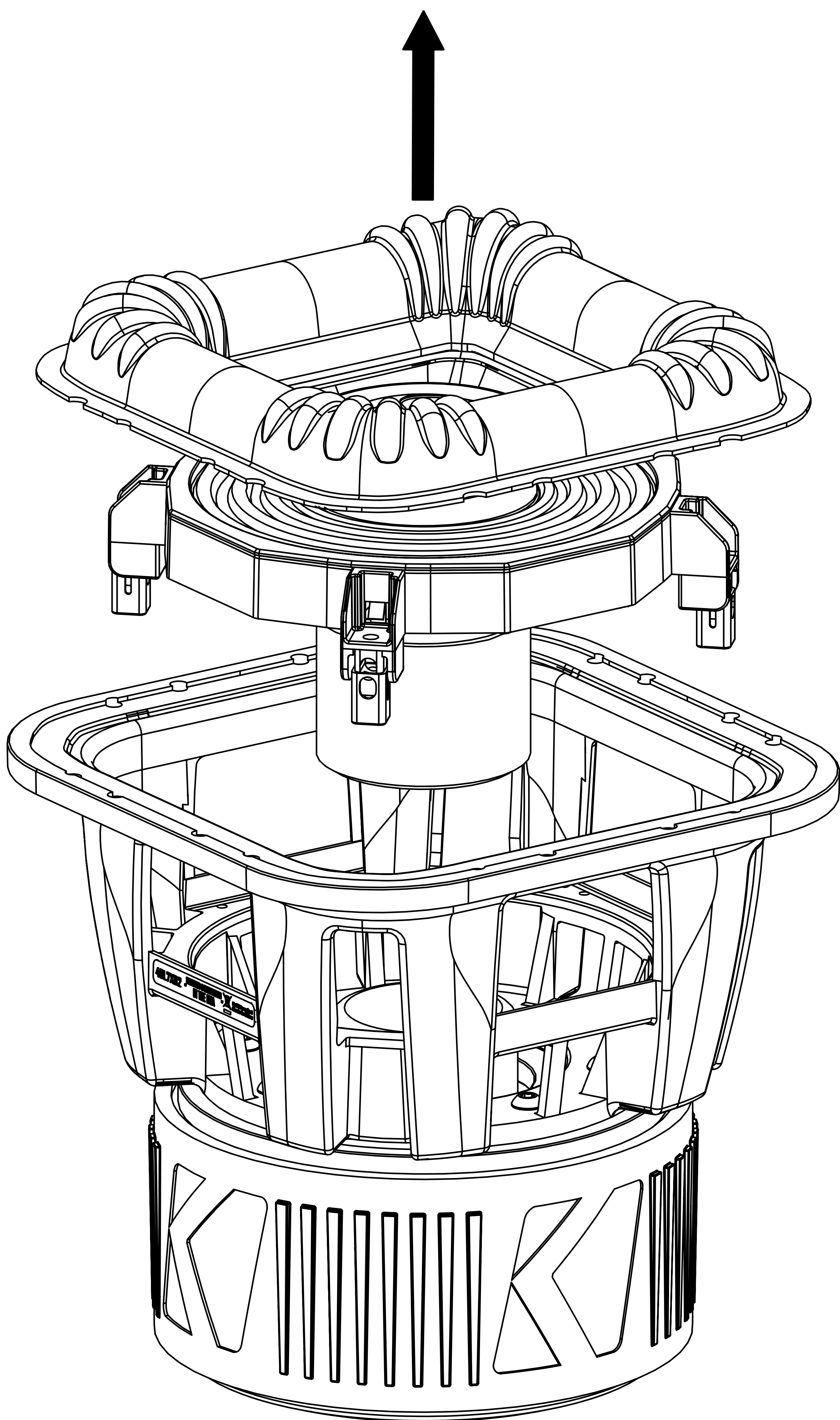

NOTE: The L7X magnet is extremely powerful. Do not allow objects containing magnetic materials to fall into voice coil gap. These objects may become stuck, rendering the subwoofer useless.

Use masking tape or a similar adhesive tape to cover or seal the voice coil gap, preventing debris from entering. Clean off any glue residue from the surround landing on the basket and the spider landing on the basket as thoroughly as possible.

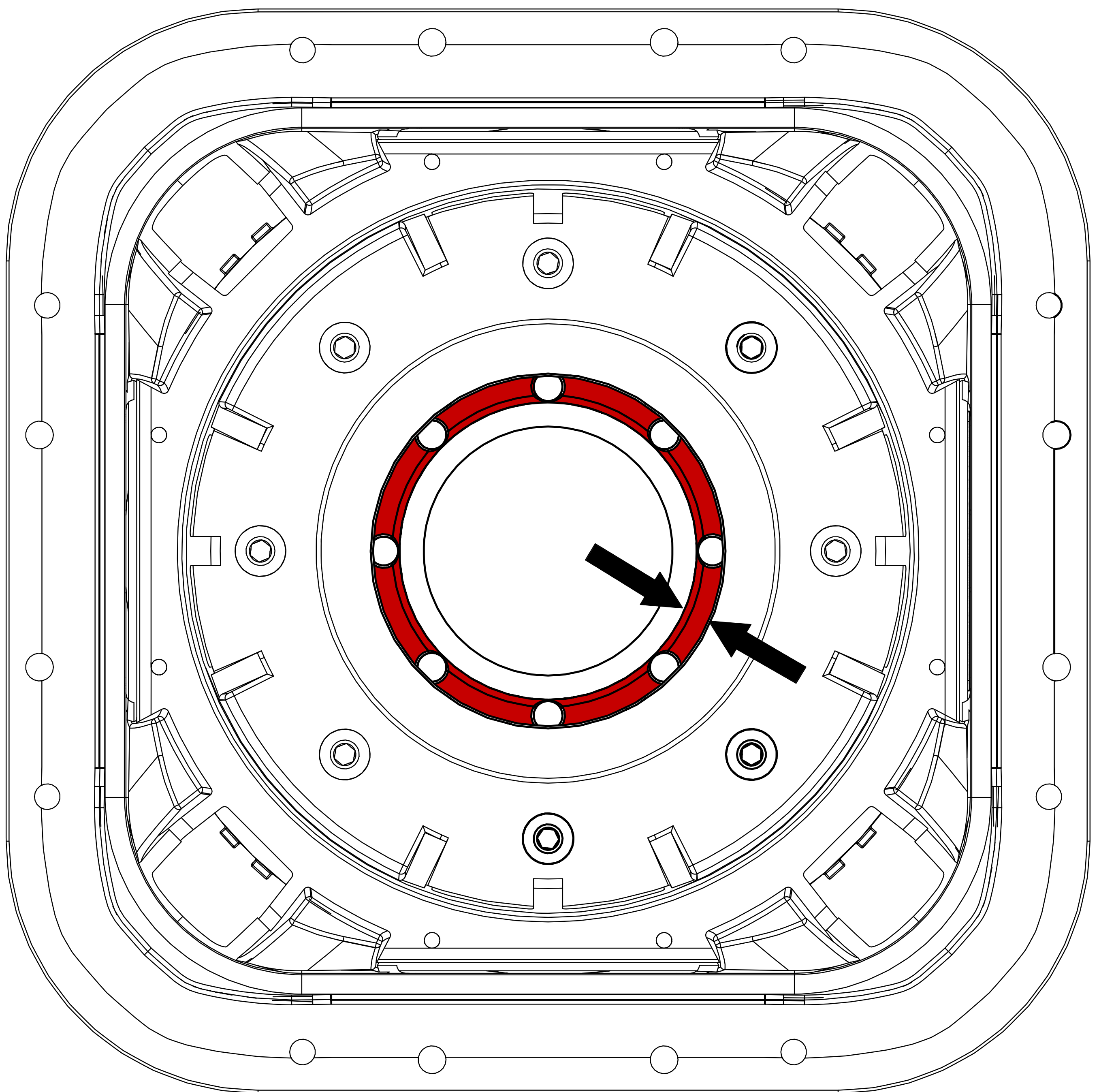

WARNING! The Voice Coil Alignment Pins are very sharp and may cause serious injury or death if handled improperly. Use caution while handling.

With the basket assembly lying on its side, insert a voice coil alignment pin into each of the eight holes of the subwoofer motor. The pin's head must contact the motor. Finesse may be required to achieve contact.

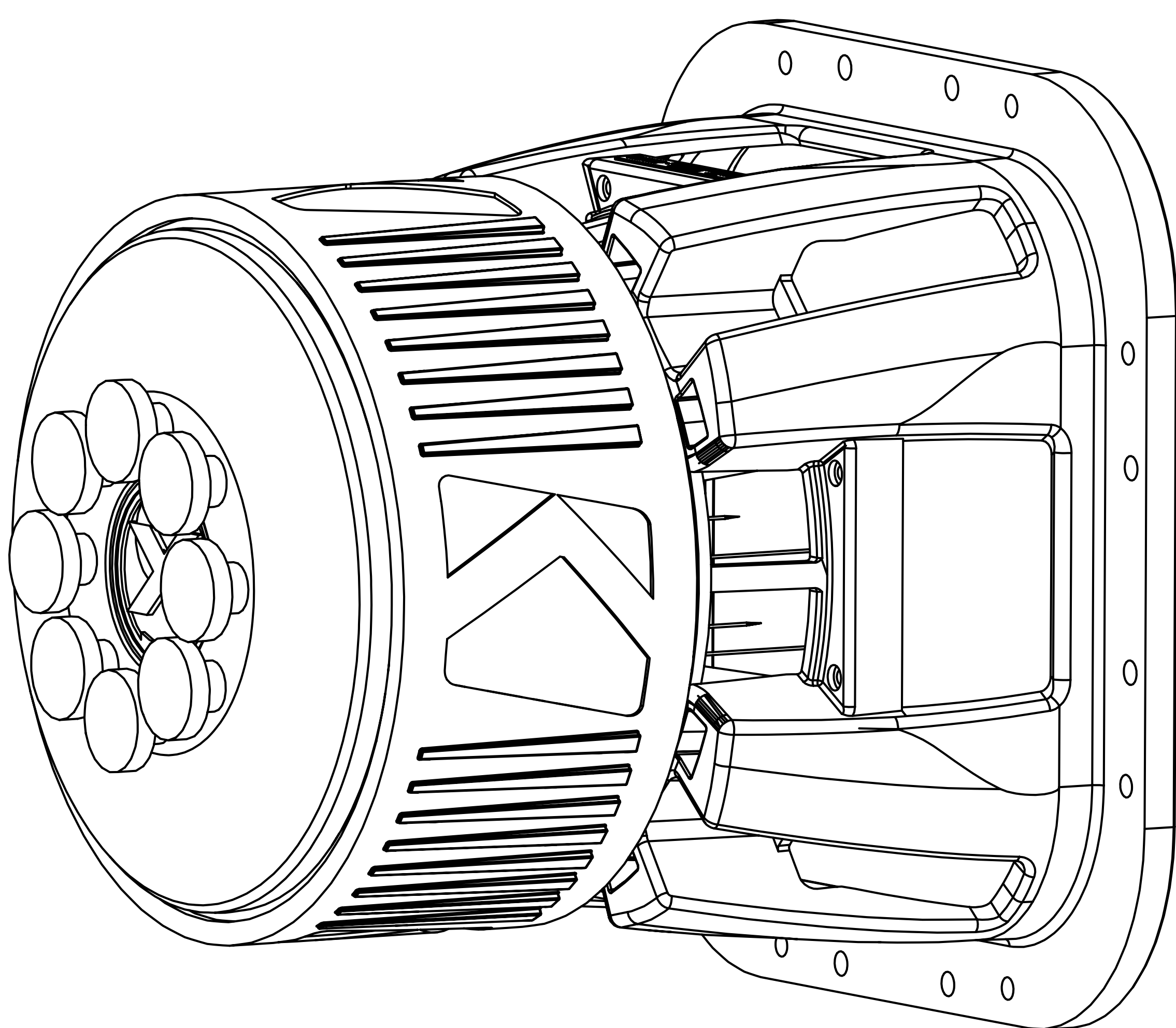
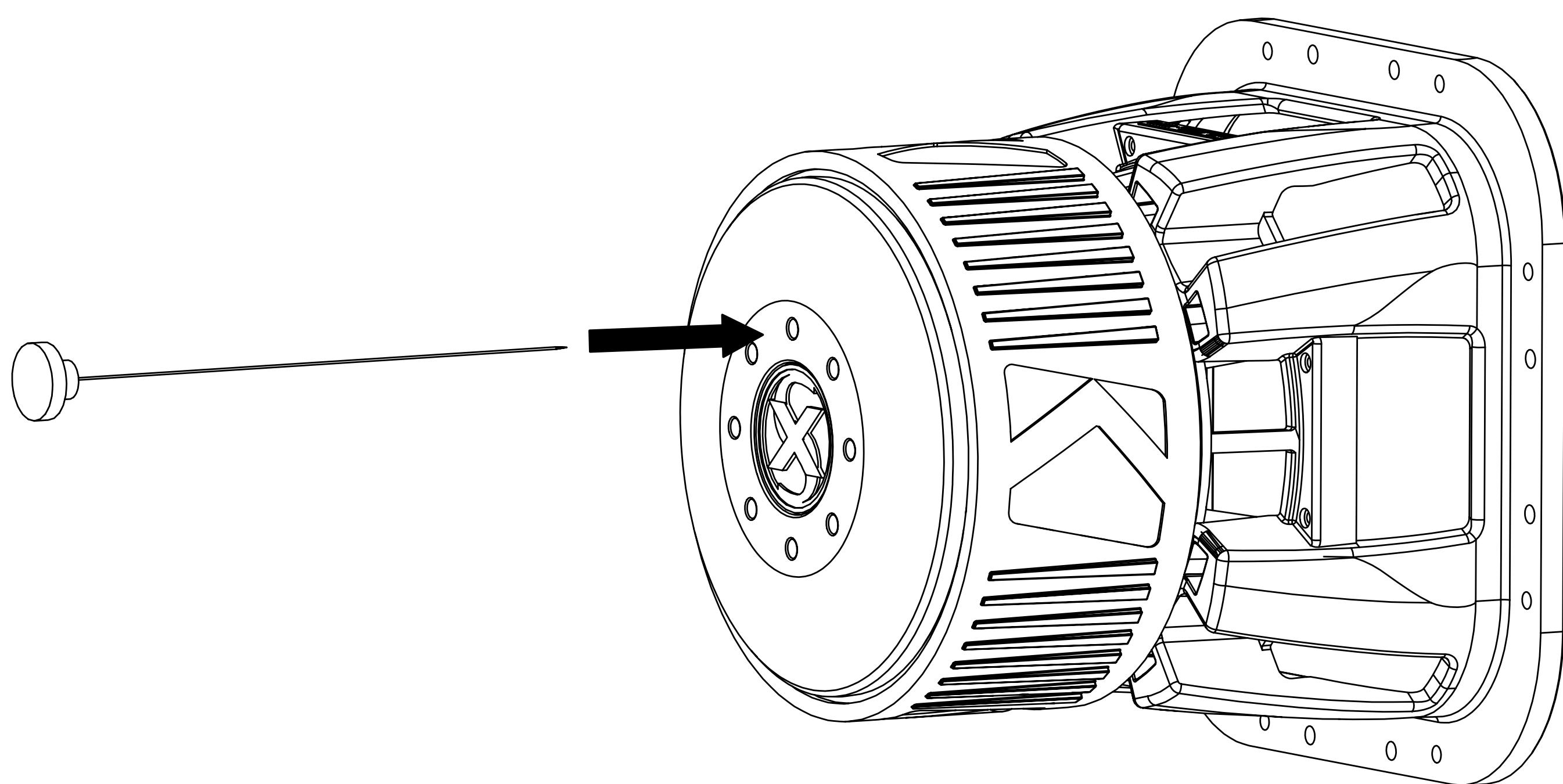

After all the voice coil alignment pins are inserted, stand the basket assembly upright and push the pins towards the pole until the pins are held to the pole magnetically. Space the pins evenly around the pole.

push the tips of all 8 pins towards the magnetic pole in the middle until they are held in place

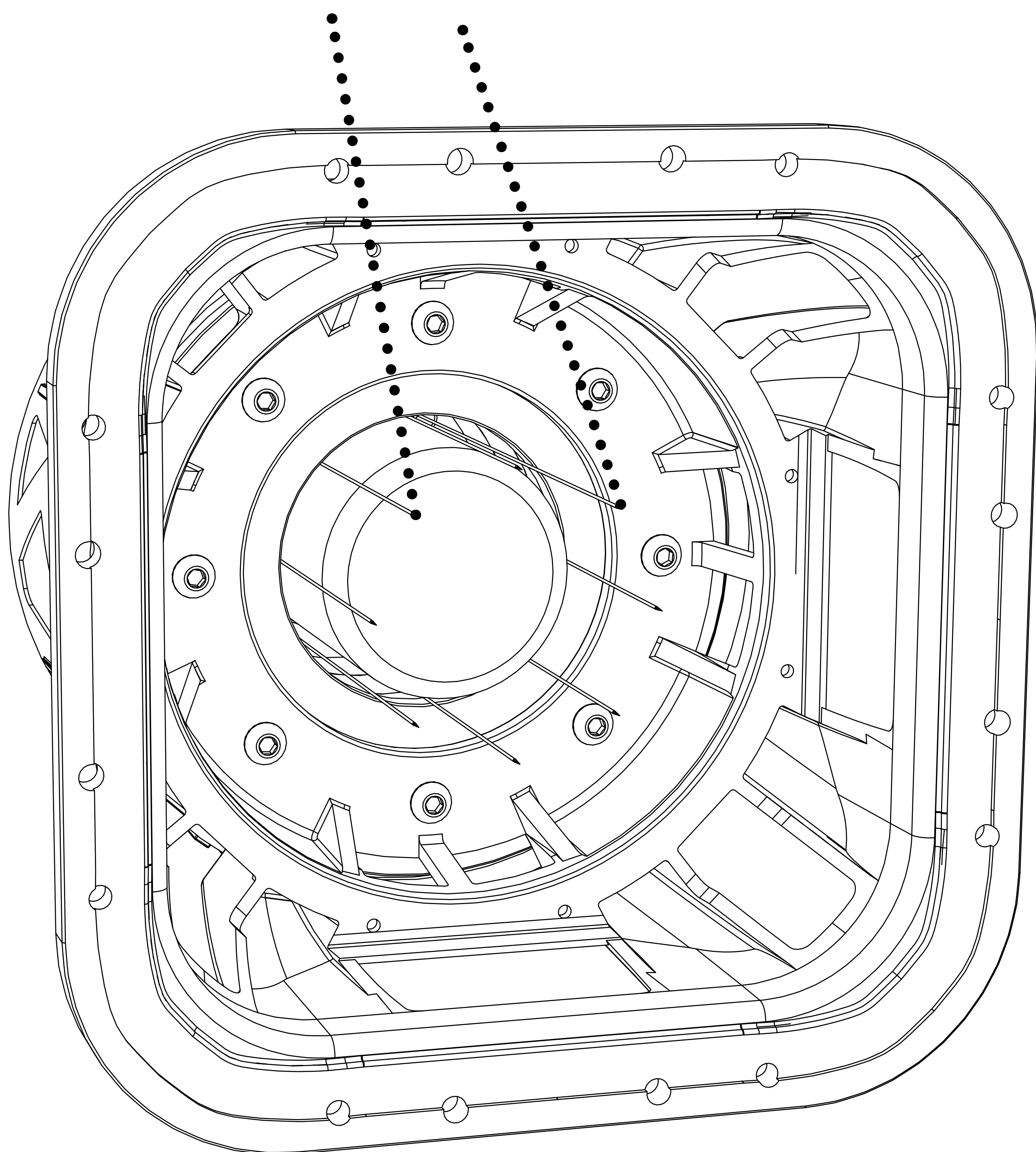

Apply glue to the highlighted areas. Use E6000 industrial-strength adhesive or better, for best results. Make sure to work in a well-ventilated area, as the adhesive may release strong fumes.

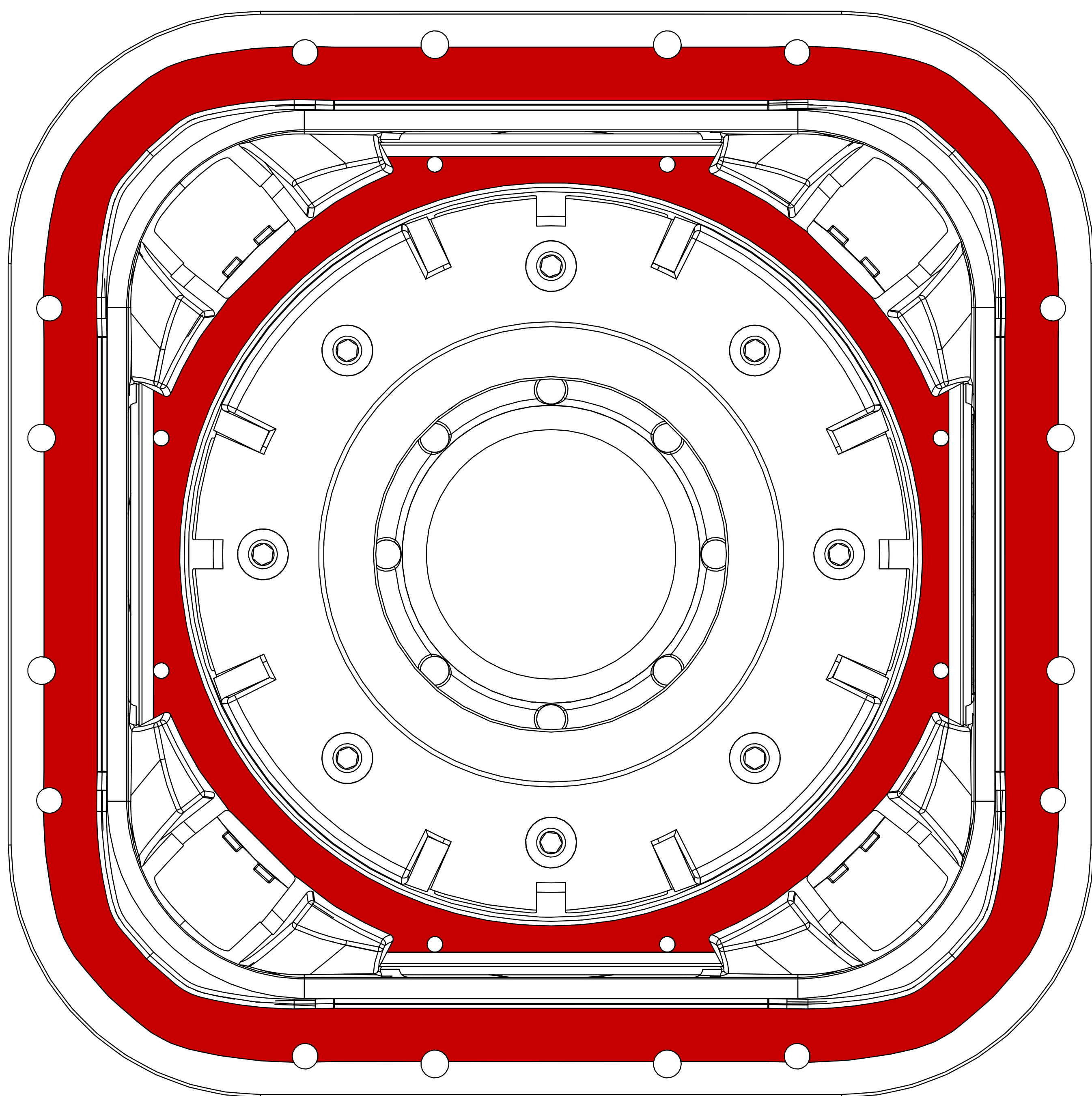

Install the cone assembly into the basket, ensuring the alignment pins remain inside the voice coil. Make sure the “S” logo on the cone aligns with the “S” logo on the bottom of the subwoofer

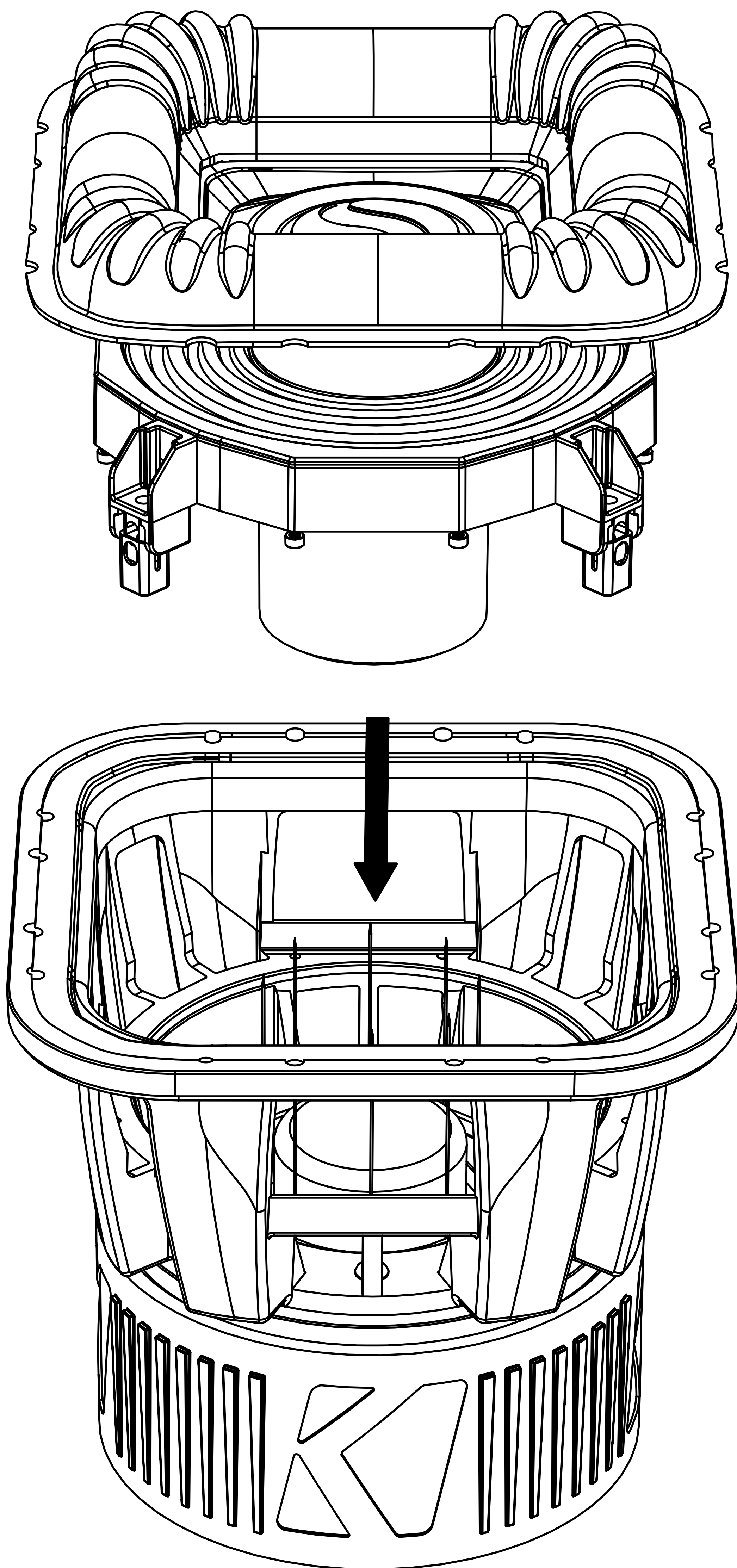

Apply glue to the highlighted portion of the cone and basket assembly.

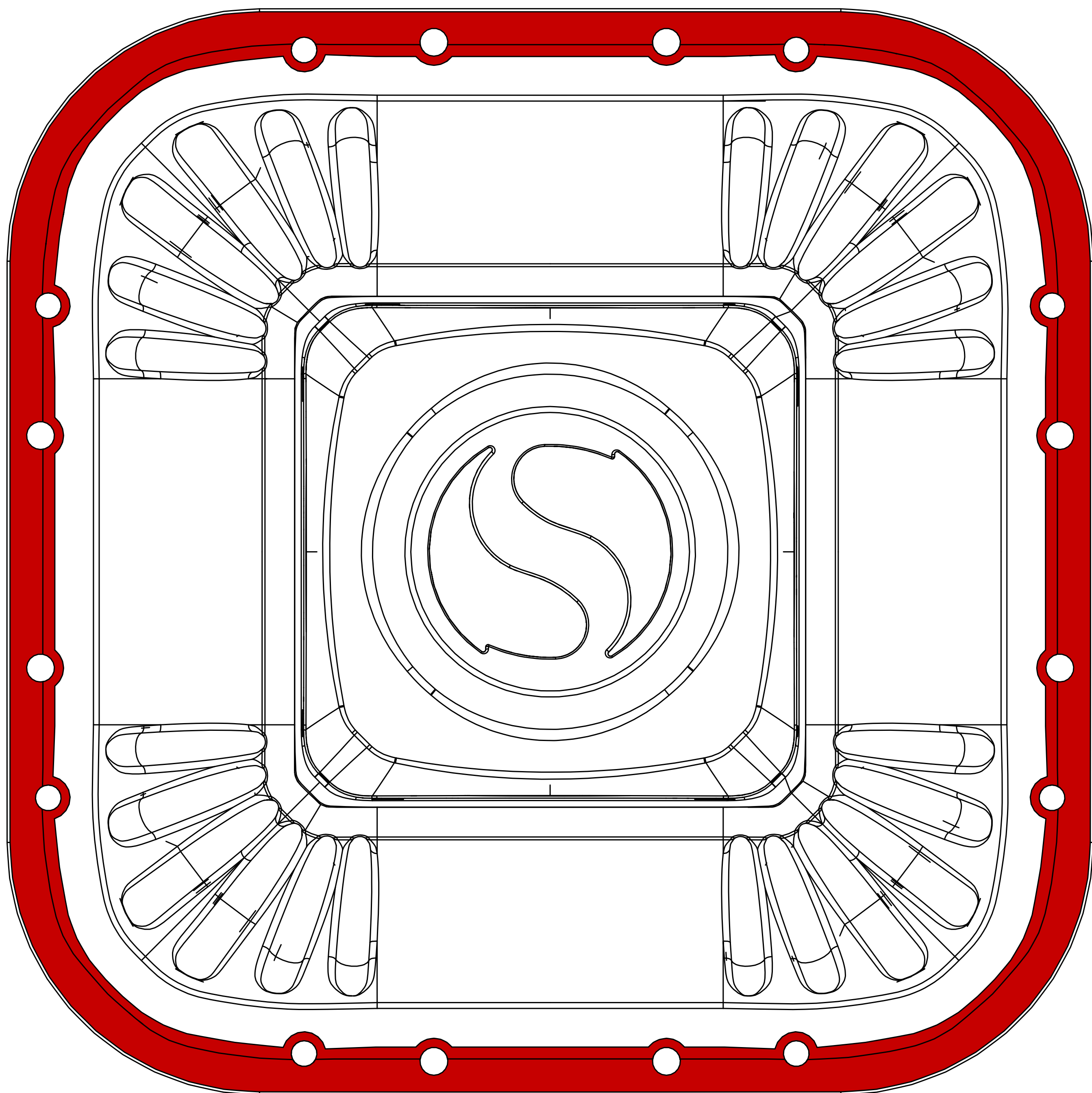

Install the surround mounting flange and clamp it to the basket assembly.

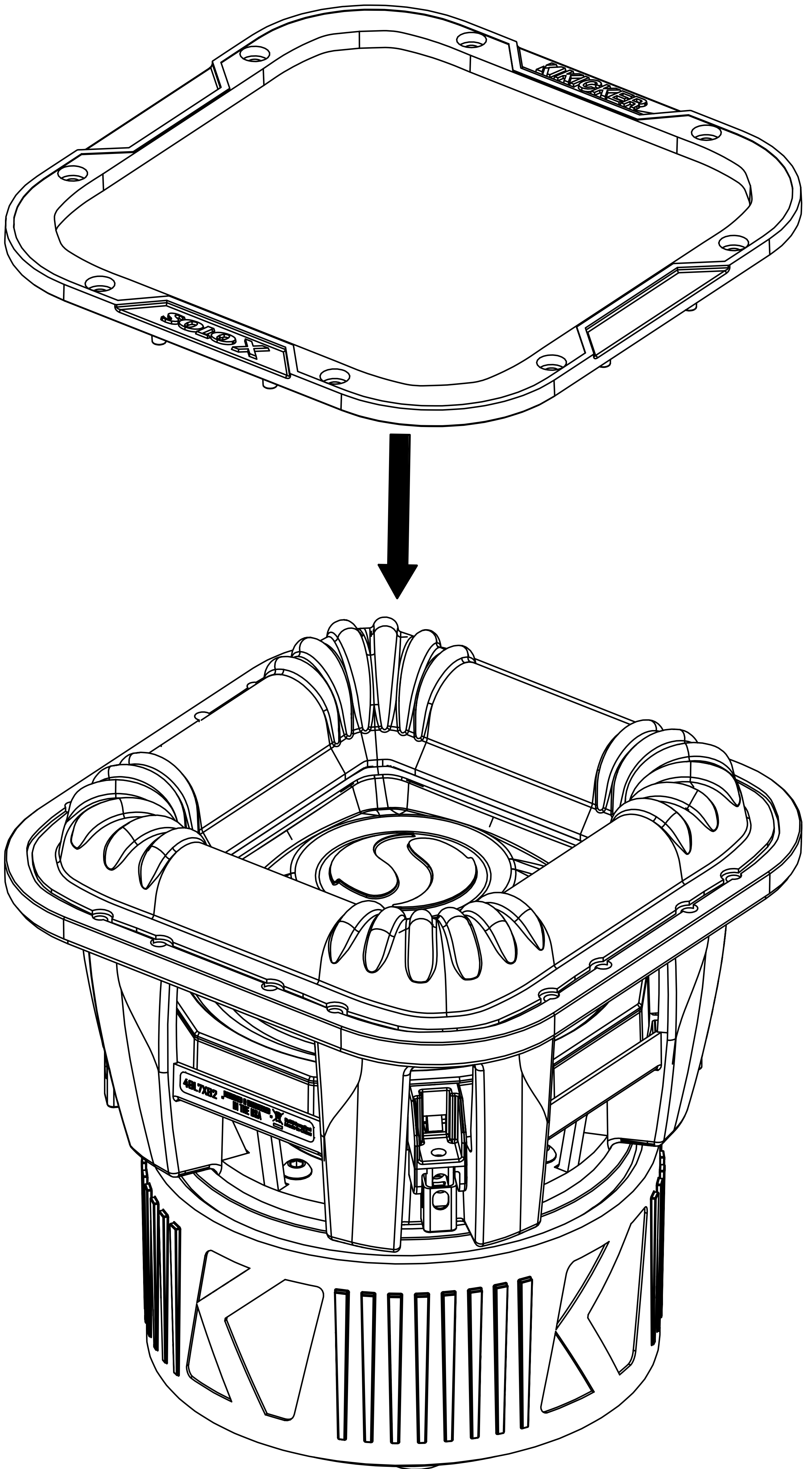

From the magnet side of the basket assembly, insert the eight M3x0.8x14mm bolts securing the cone assembly to the basket assembly using a 2.5mm Allen wrench.

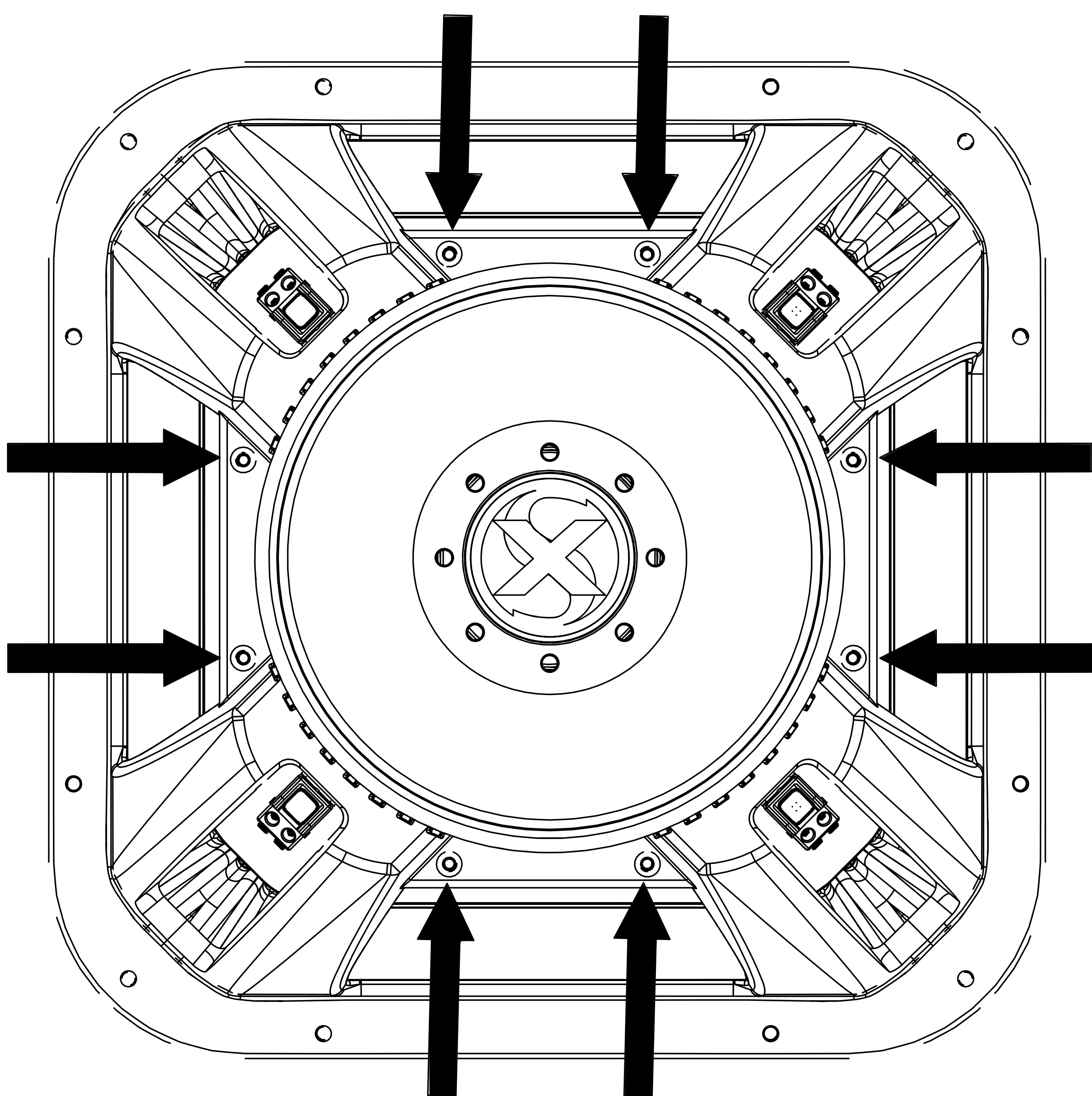

Allow the glue to cure for 72hrs. Remove the voice coil alignment pins from the motor before using the subwoofer.

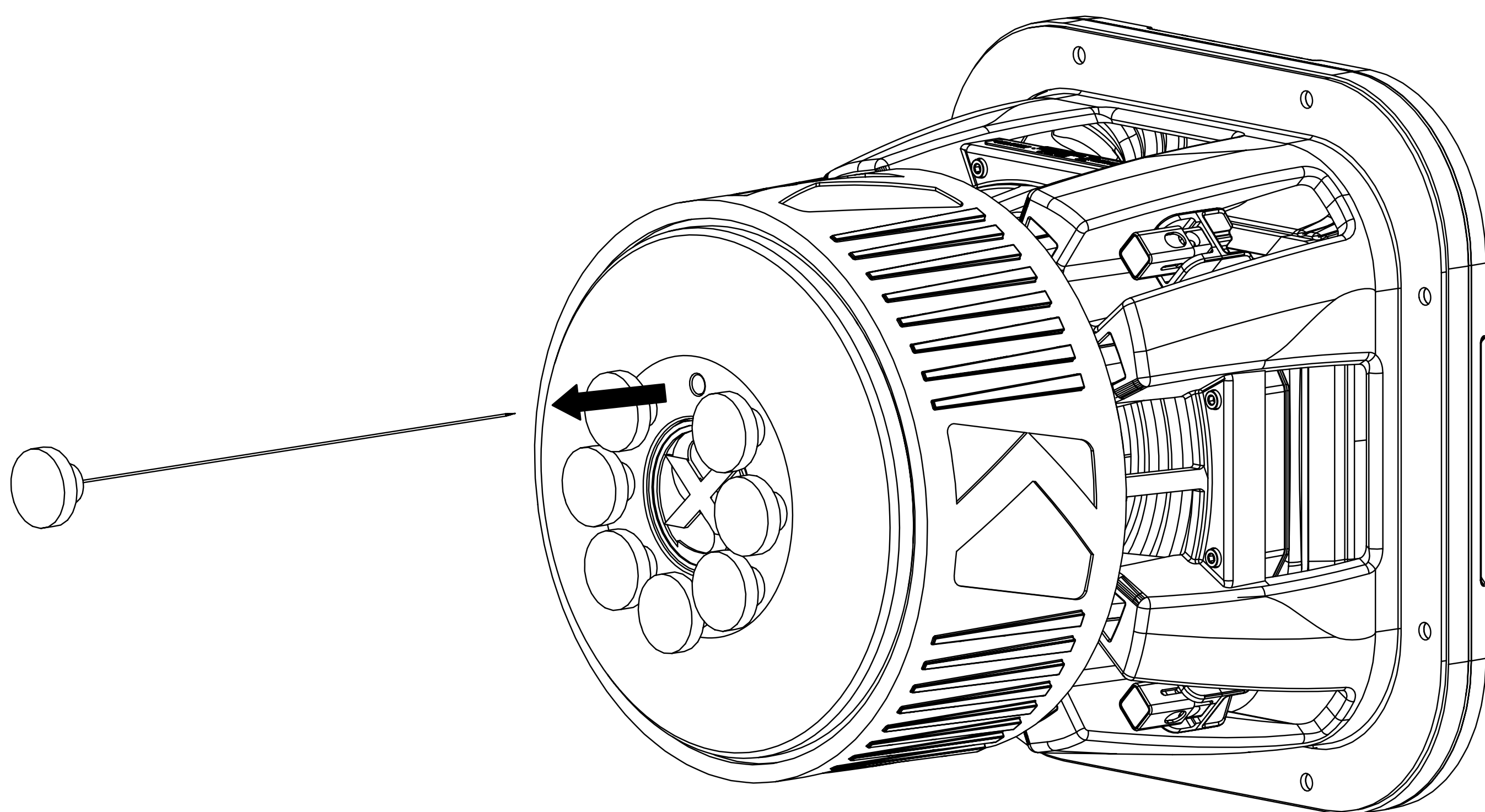

L7X10–L7X18 Re-cone

The larger L7X models have been designed for competitive use and, because there is no glue utilized in the re-cone process, the cone can be replaced in minutes if failure occurs in the field.

These Re-Cone Assemblies consist of a pre-assembled cone, surround, and voice coil that will be bolted into the L7X motor and Basket Assembly, and can be purchased on the KICKER website [here](#). Do **NOT** attempt to use alternate impedance Recone Kits when rebuilding the subwoofer. For example, only use the 1-ohm Recone Kit in the 1-ohm L7X subwoofer structure.

Use the following steps to rebuild the L7X.

Do not use power tools for this rebuild! The L7X magnet is extremely powerful and may cause personal injury or damage to items. Use caution around objects that contain magnetic material.

Begin by removing the subwoofer from its mounting location and disconnecting all wiring.

Using a 4mm Allen Wrench, remove the eight M5x0.8x10mm bolts securing the Surround Mounting Flange to the Basket Assembly.

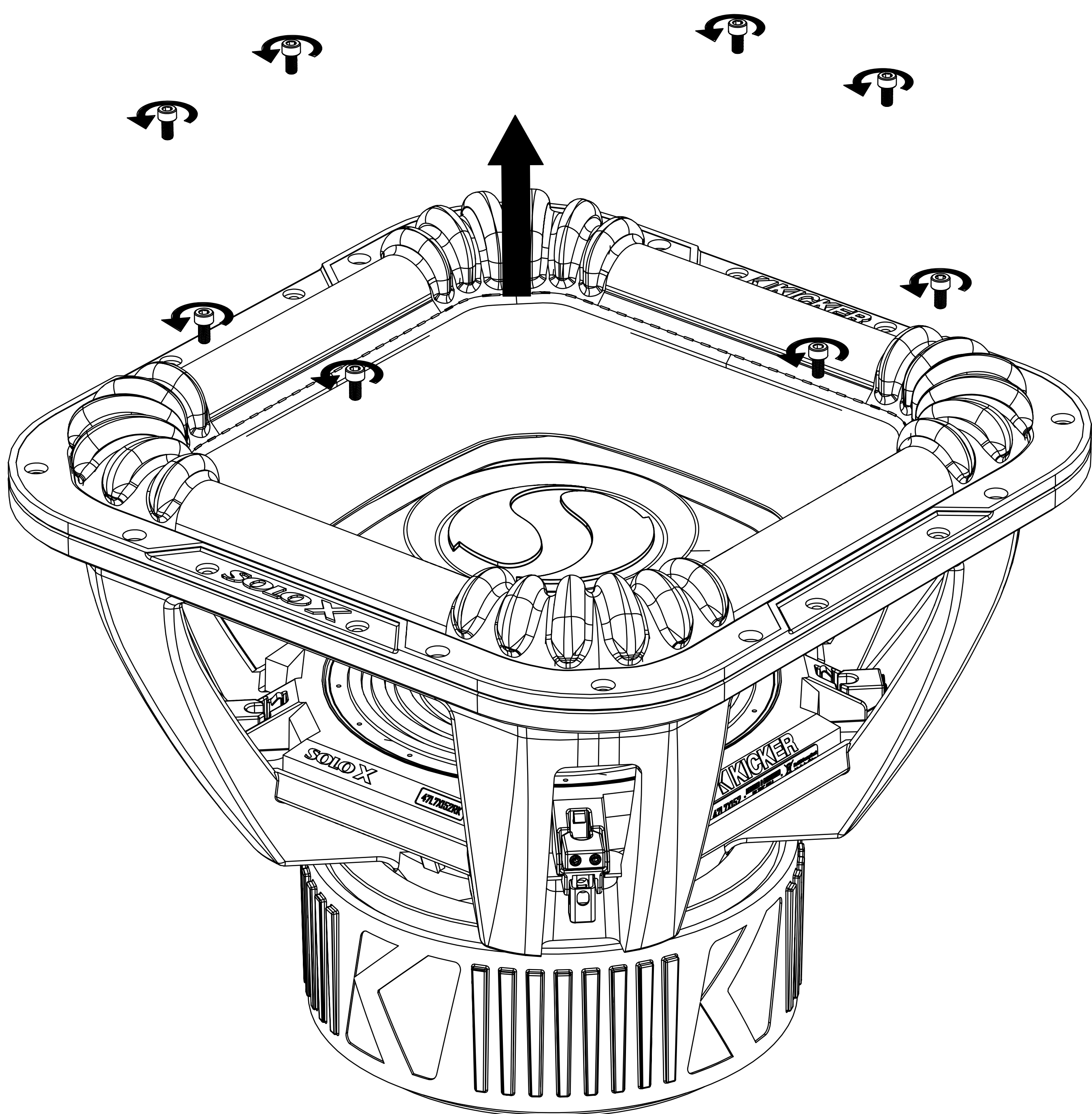

Remove the Surround Mounting Flange from the Basket Assembly.

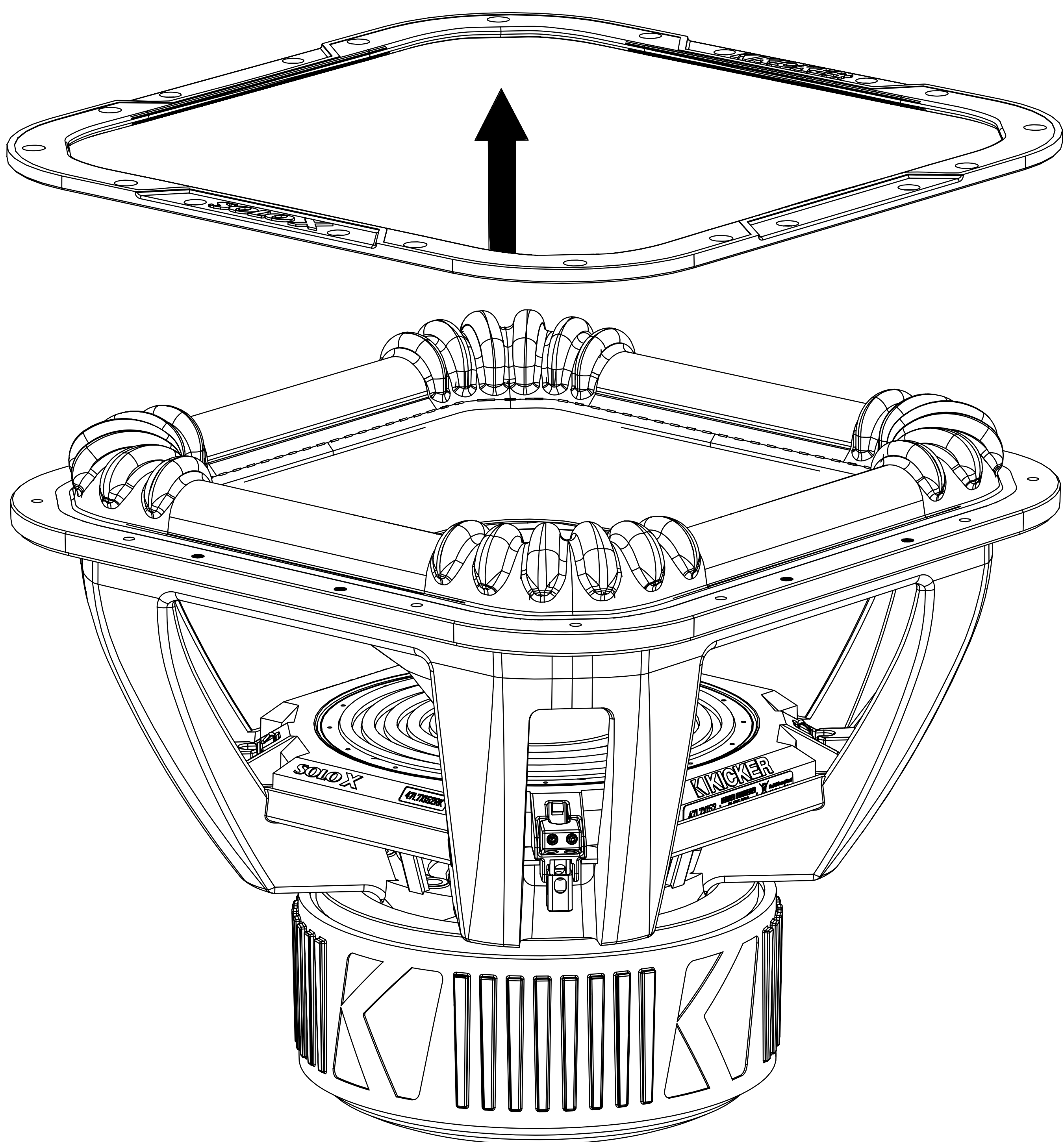

From the magnet side (bottom) of the Basket Assembly, use a 4mm Allen Wrench to remove the eight M5x0.8x16mm bolts securing the Spider to the Basket Assembly.

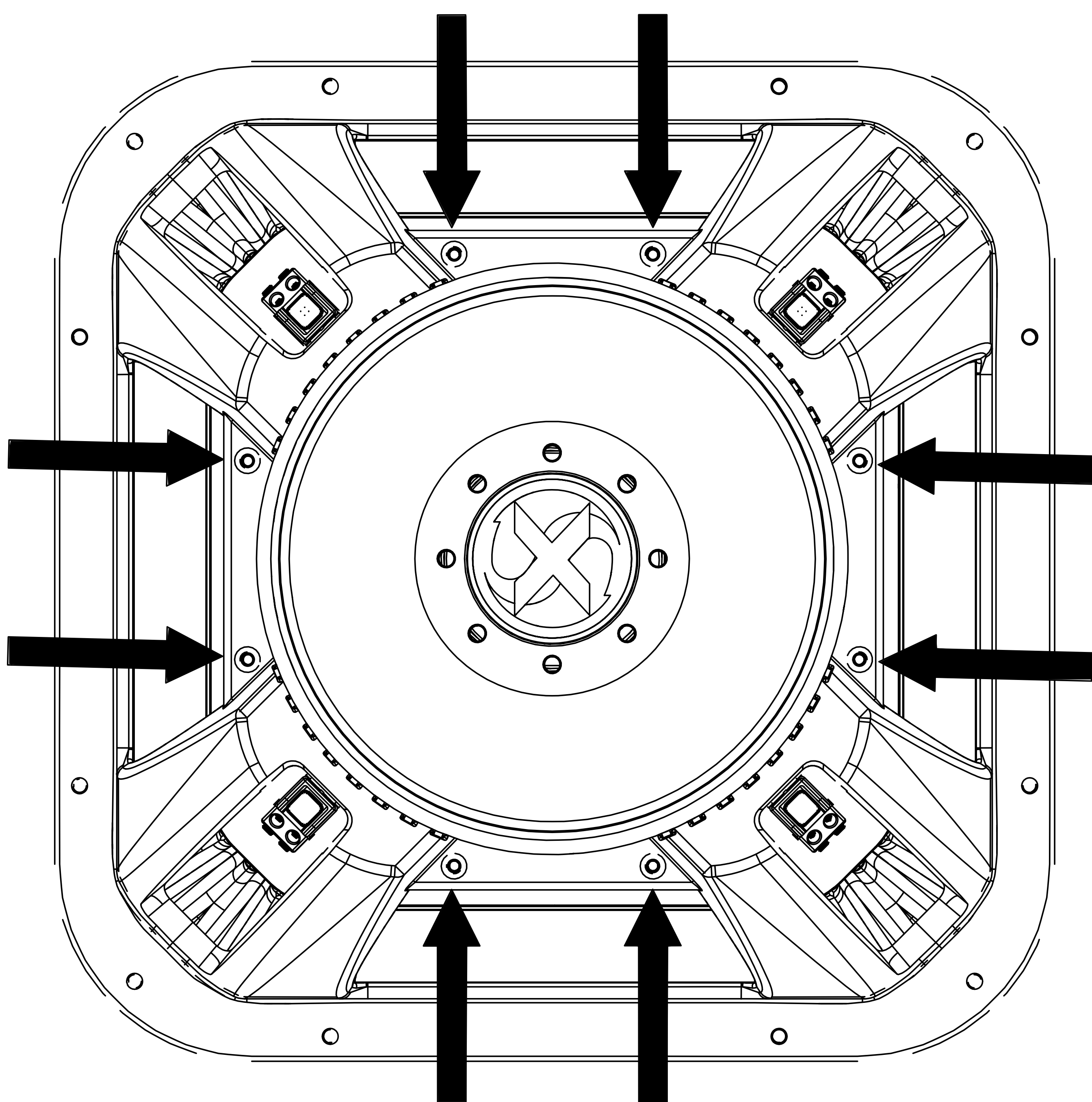

From the cone side (top) of the Basket Assembly, pull the Cone Assembly out of the Basket Assembly.

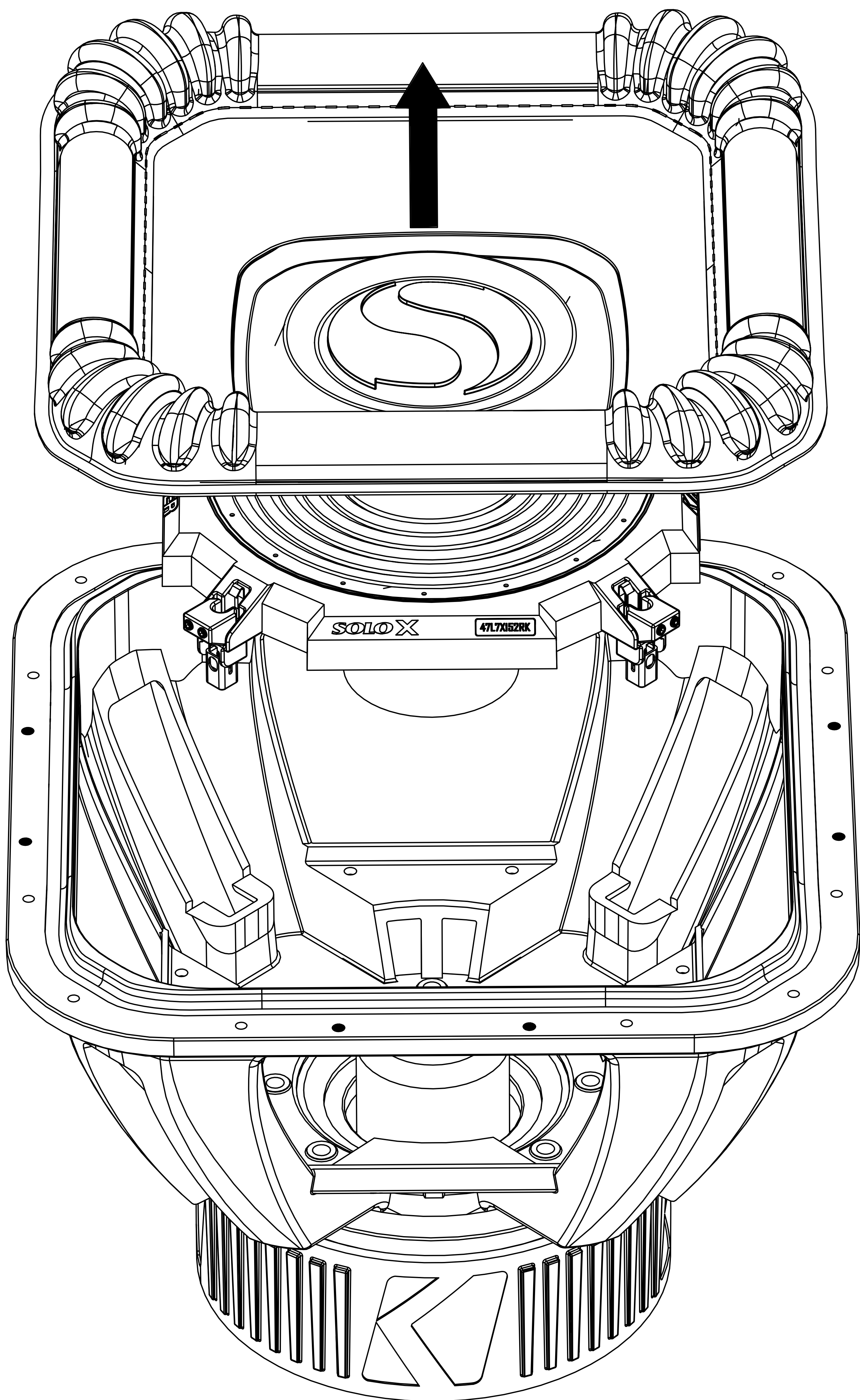

Clean and remove all debris from the Voice Coil Gap.

NOTE: The L7X magnet is extremely powerful. Do not allow objects containing magnetic materials to fall into voice coil gap. These objects may become stuck, rendering the subwoofer useless.

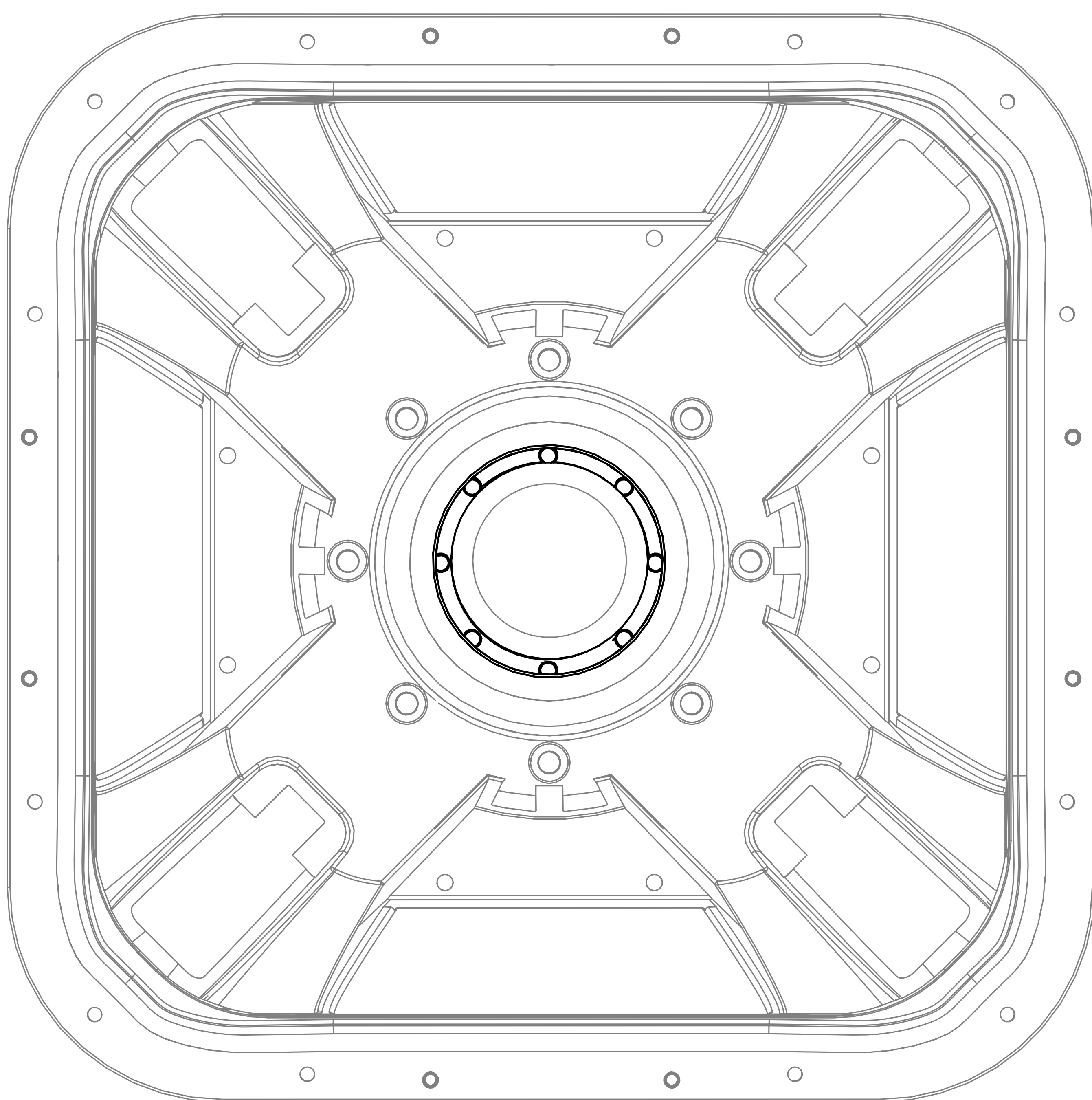

WARNING! The Voice Coil Alignment Pins are very sharp and may cause serious injury or death if handled improperly. Use caution while handling.

With the Basket Assembly laying on its side, insert a Voice Coil Alignment Pin into each of the eight holes of the subwoofer motor. The pin's head must contact the motor. Finesse may be required to achieve contact.

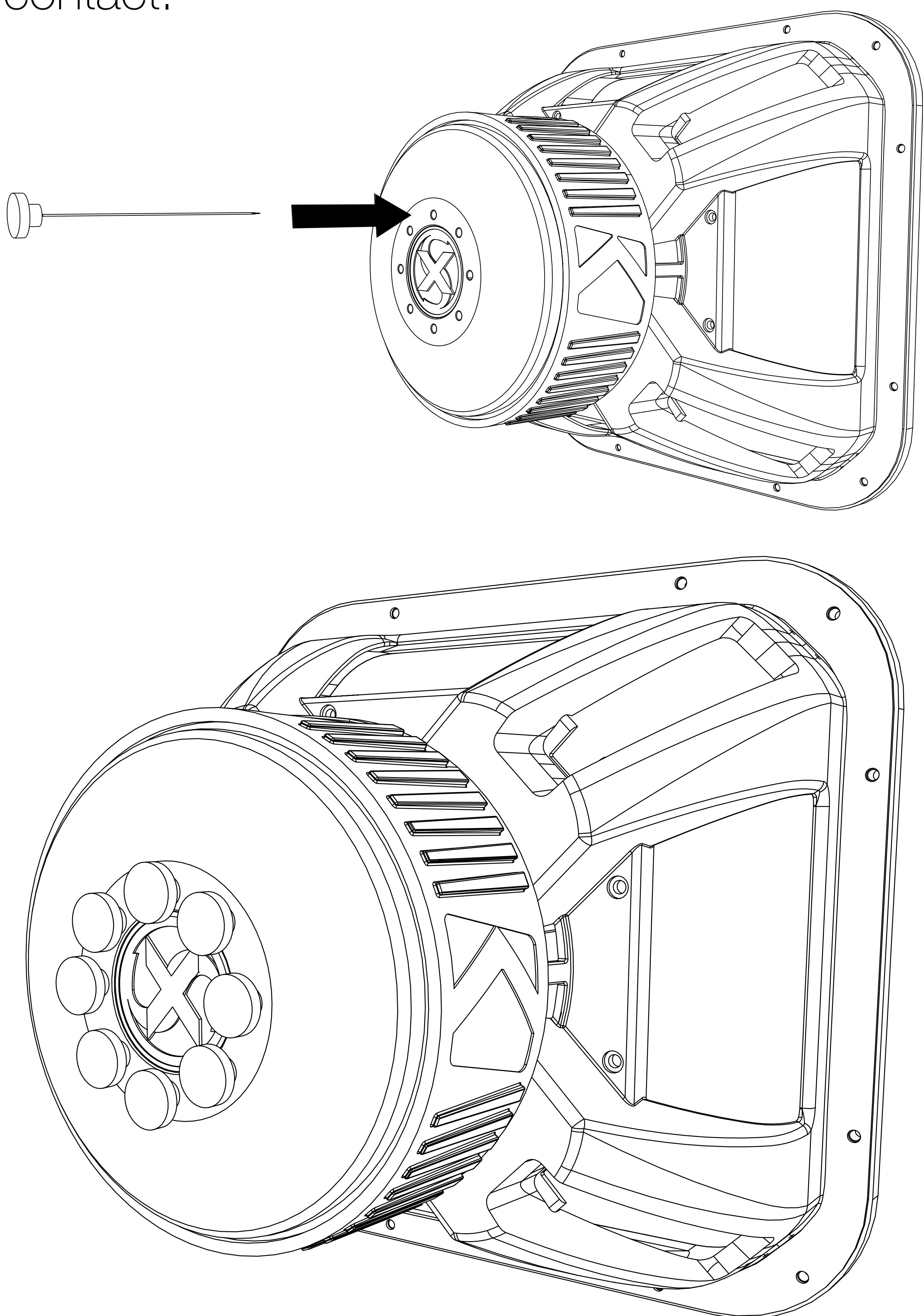

After all the Voice Coil Alignment Pins are inserted, push the pins towards the pole until the pins are held to the pole magnetically. Space the pins evenly around the pole.

push the tips of all 8 pins towards the magnetic pole in the middle until they are held in place

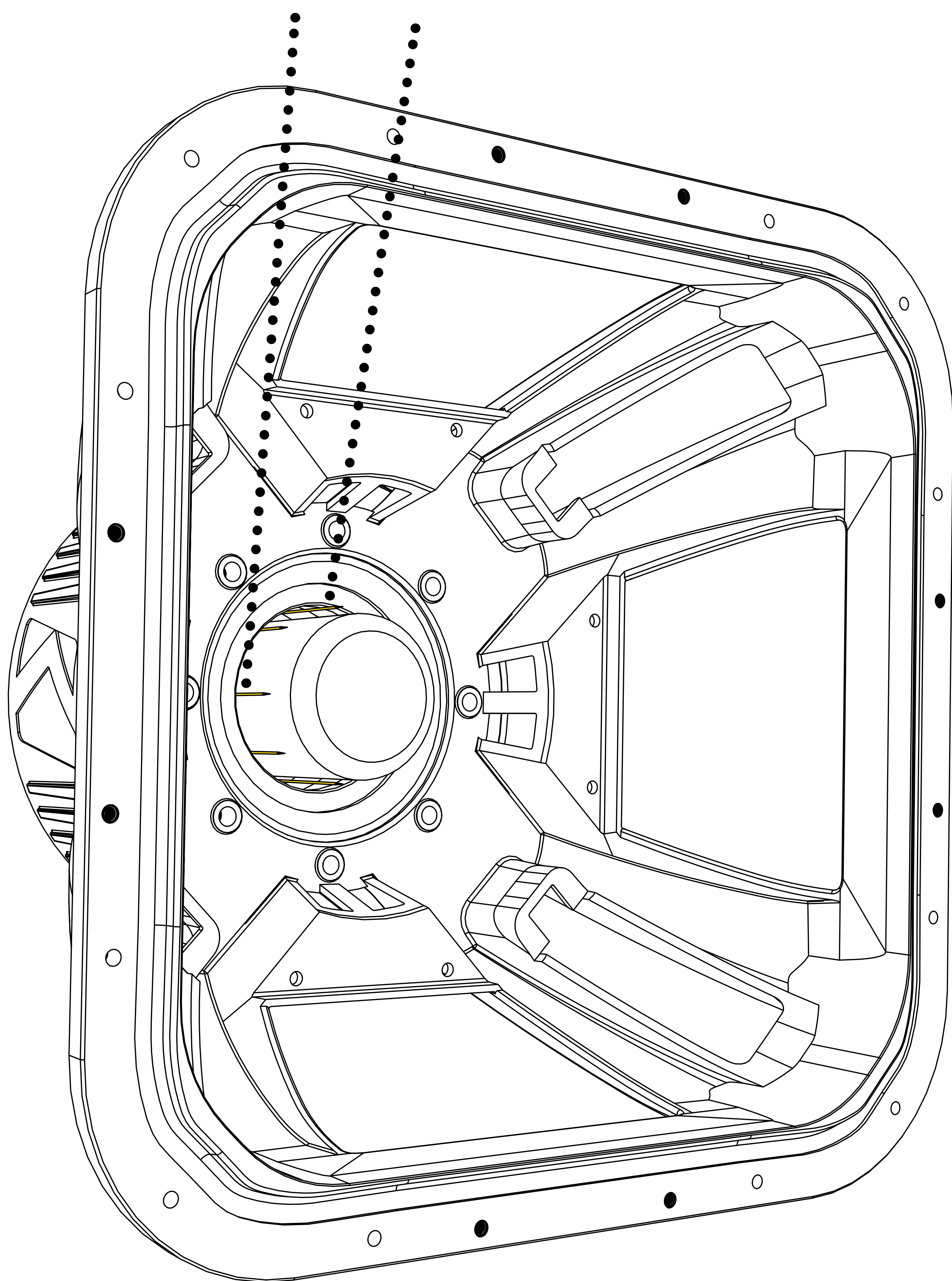

With the Basket Assembly still laying on its side, insert the new Cone Assembly into the Basket Assembly. Pay close attention and ensure that the pins lay inside of the voice coil, allowing the voice coil to smoothly slide into place over the magnetic pole.

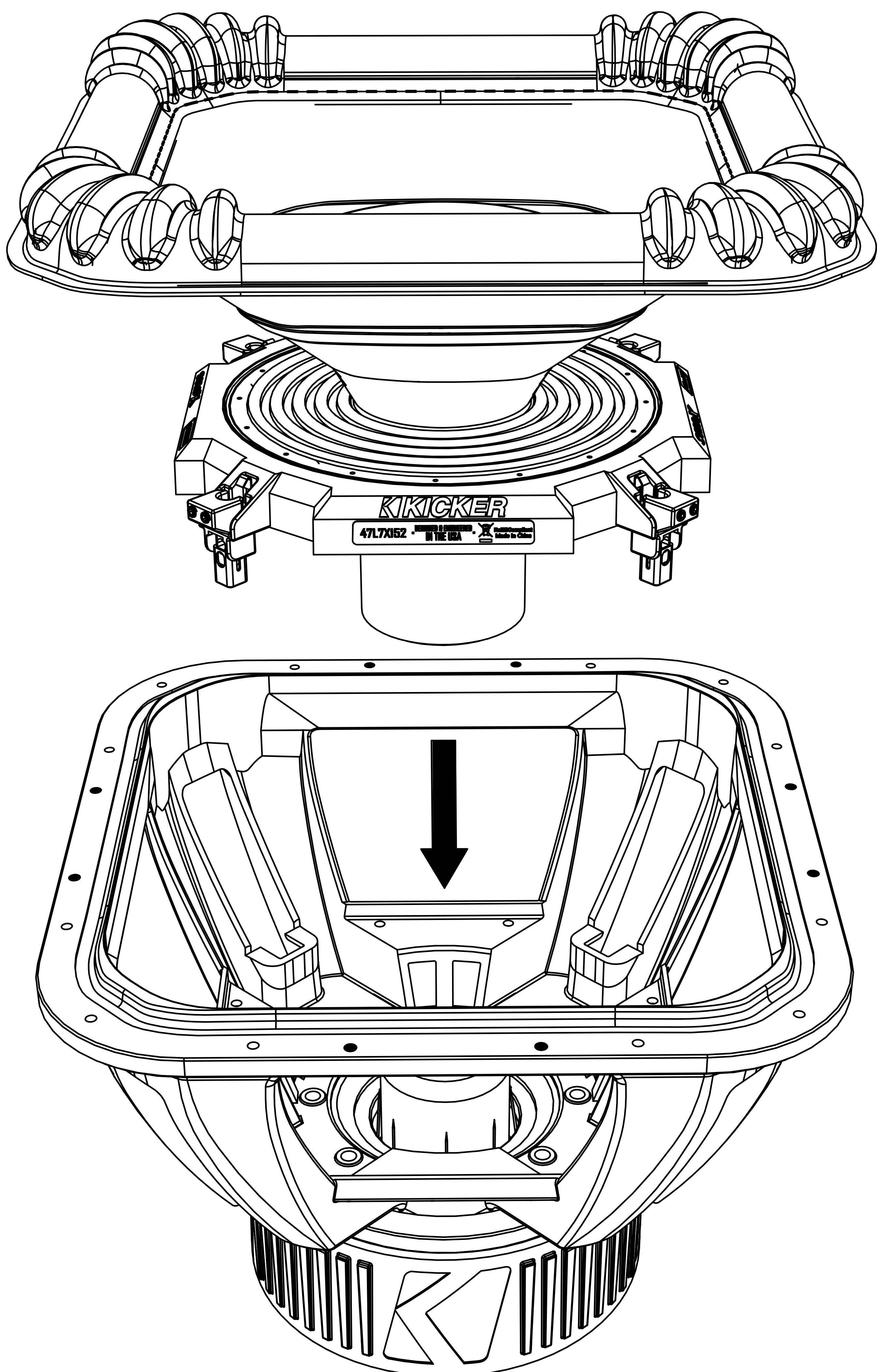

Secure the Spider to the Basket Assembly using the eight M5x0.8x16mm bolts. Loosely start all bolts before tightening. Torque the bolts to 20in-lbs in the sequence shown below.

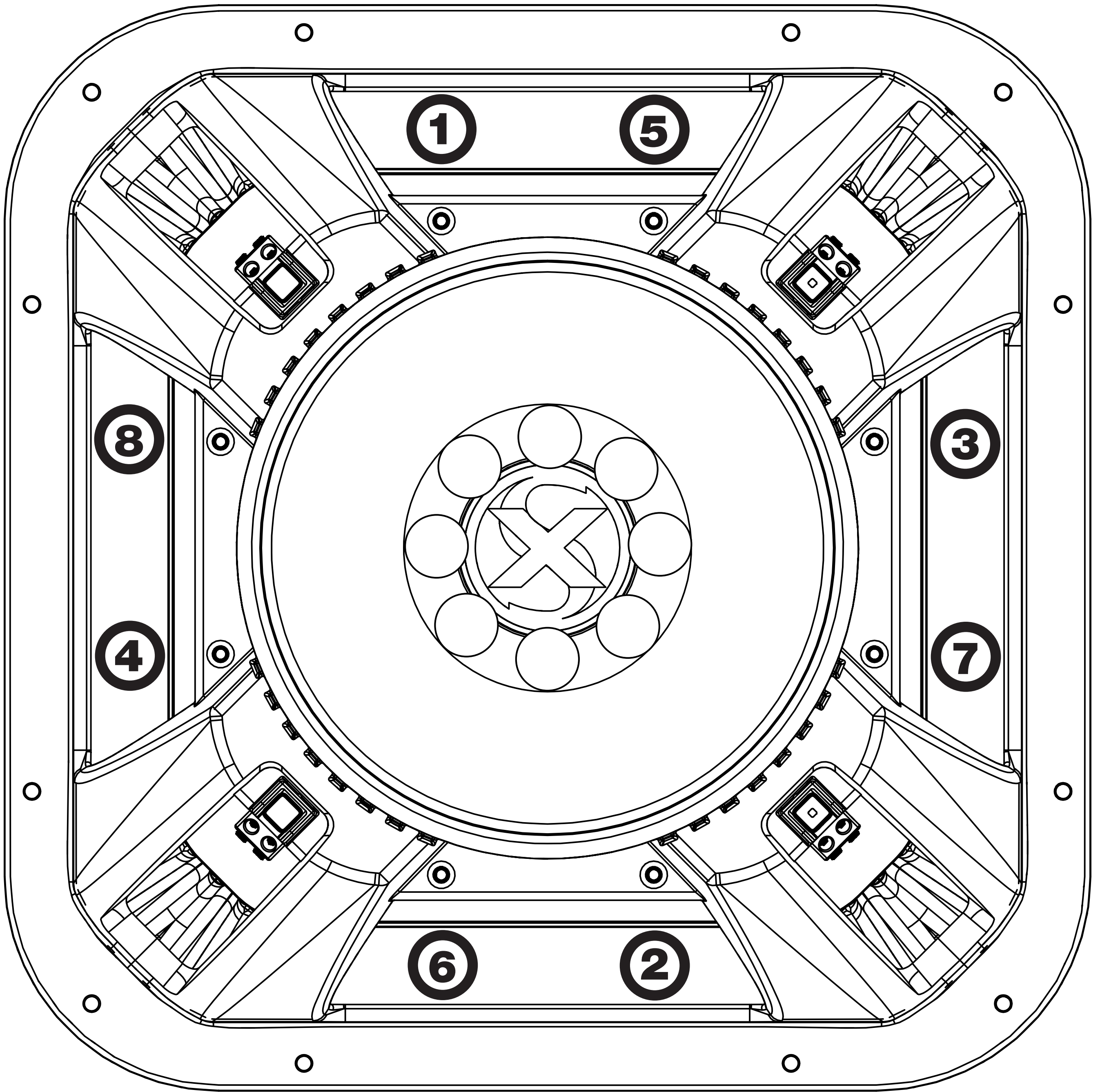

Turn speaker upright and install the Surround Mounting Flange over the Surround.

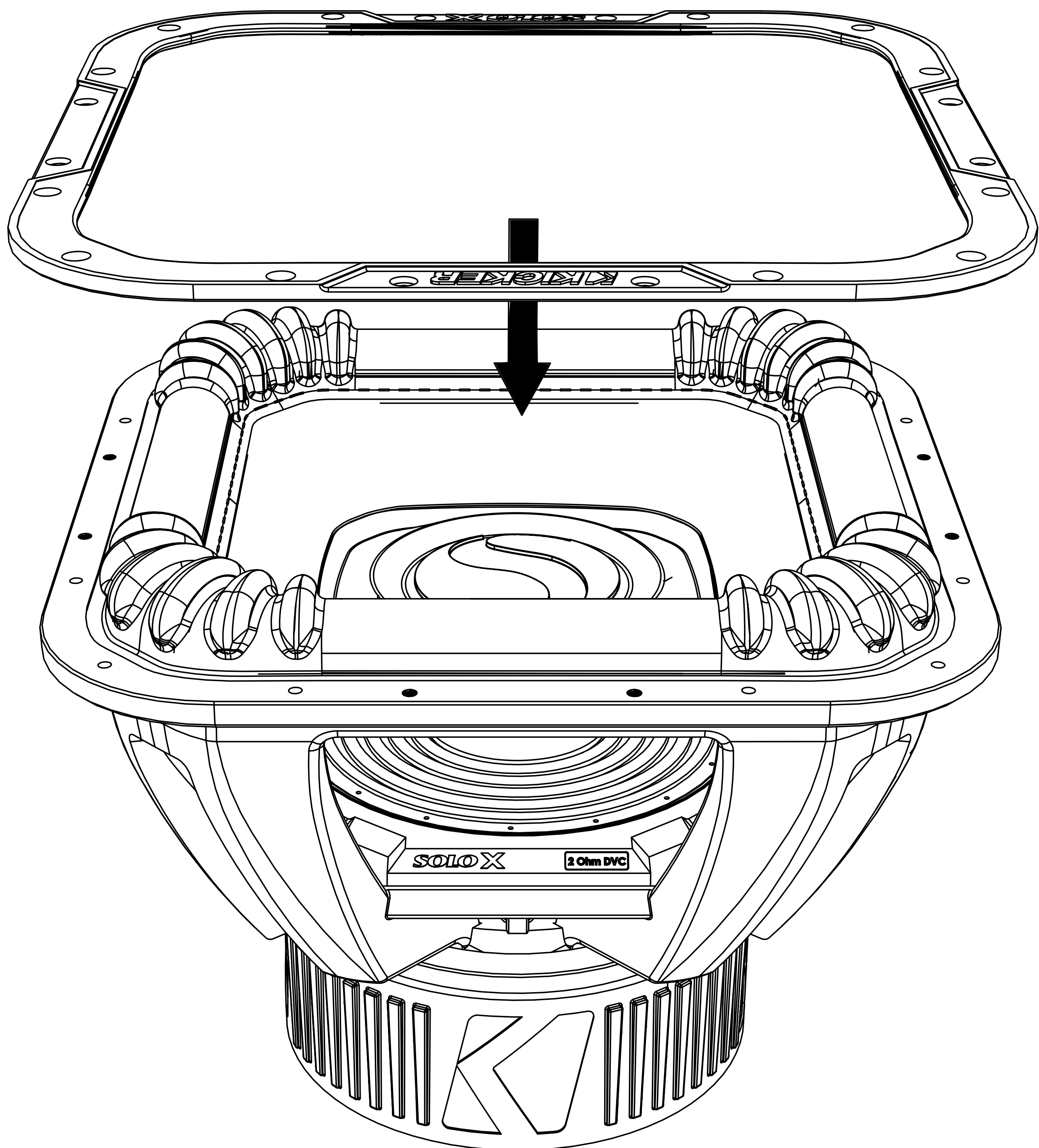

Secure the Surround Mounting Flange to the basket with the eight M5x0.8x10mm bolts. Loosely start all bolts before tightening. Torque bolts to 20in-lbs in the sequence shown below.

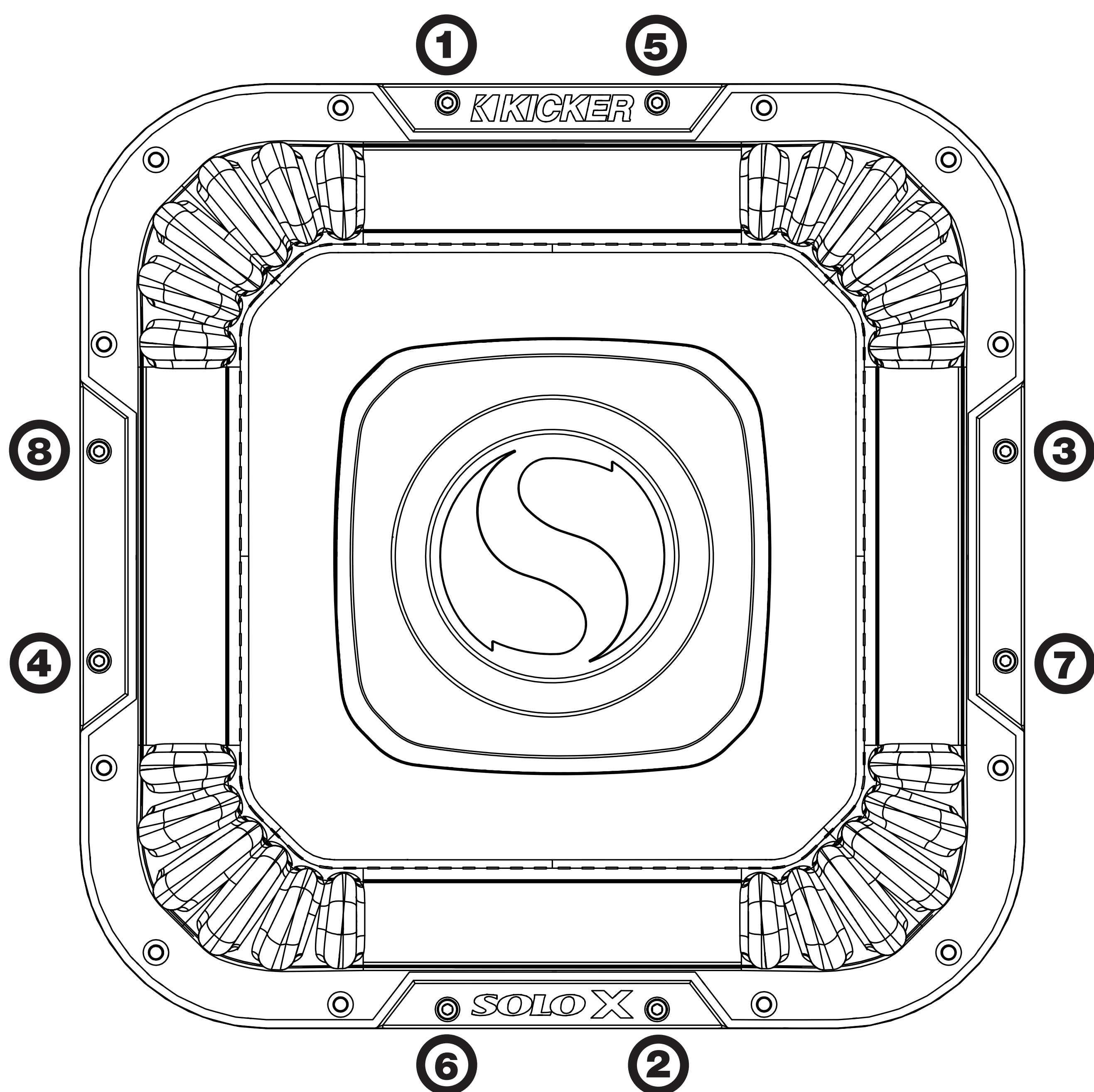

Remove the Voice Coil Alignment Pins from the motor.

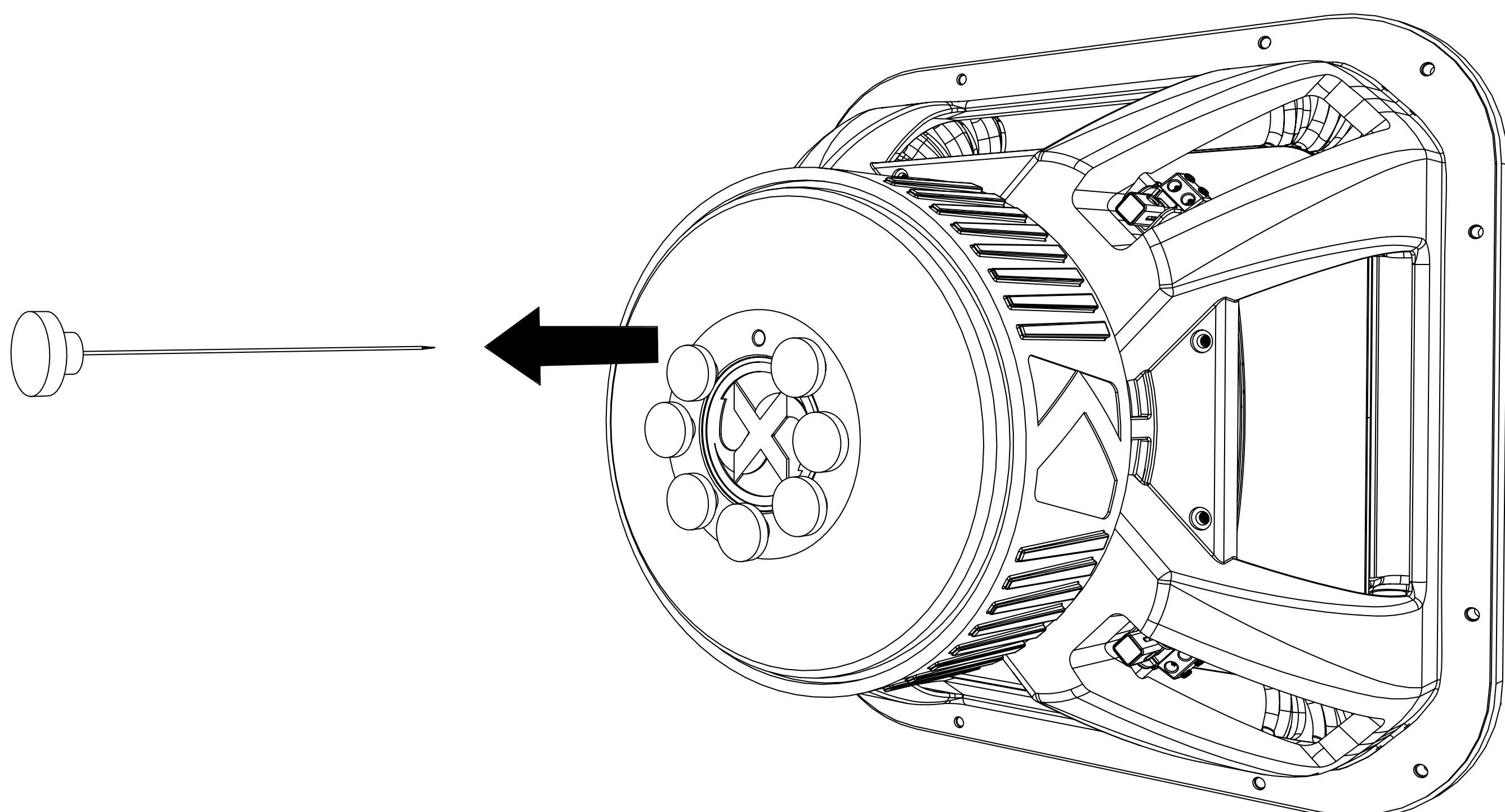

Warranty

When purchased from an Authorized KICKER Dealer, KICKER warrants this product to be free from defects in material and workmanship under normal use for a period of ONE (1) YEAR from date of original purchase with receipt. If this product is identified as “Refurbished” or “B Goods”, the warranty is limited to a period of THREE (3) MONTHS from the date of original purchase. In all cases you must have the original receipt. Should service be necessary under this warranty for any reason due to manufacturing defect or malfunction during the warranty period, KICKER will repair or replace (at its discretion) the defective merchandise with equivalent merchandise. Warranty replacements may have cosmetic scratches and blemishes. Discontinued products may be replaced with more current equivalent products. This warranty is valid only for the original purchaser and is not extended to owners of the product subsequent to the original purchaser. Any applicable implied warranties are limited in duration to a period of the express warranty as provided herein beginning with the date of the original purchase at retail, and no warranties, whether express or implied, shall apply to this product thereafter. Some states do not allow limitations on implied warranties; therefore, these exclusions may not apply to you. This warranty gives you specific legal rights; however you may have other rights that vary from state to state.

WHAT TO DO IF YOU NEED WARRANTY OR SERVICE:

Defective merchandise should be returned to your local Authorized Stillwater Designs (KICKER) Dealer for warranty service. Assistance in locating an Authorized Dealer can be found at www.KICKER.com or by contacting Stillwater Designs directly. You can confirm that a dealer is authorized by asking to see a current authorized dealer window decal.

If it becomes necessary for you to return defective merchandise directly to Stillwater Designs (KICKER), call the KICKER Customer Service Department at (405) 624-8510 for a Return Merchandise Authorization (RMA) number. Package only the defective items in a package that will prevent shipping damage, and return to:

Stillwater Designs
3100 North Husband St
Stillwater, OK 74075

The RMA number must be clearly marked on the outside of the package. Please return only defective components. The return of functioning items increases your return freight charges. Non-defective items will be returned freight collect to you. For example, if a subwoofer is defective, only return the defective subwoofer, not the entire enclosure. Include a copy of the original receipt with the purchase date clearly visible, and a “proof-of-purchase” statement listing the Customer’s name, Dealer’s name and invoice number, and product purchased. Warranty expiration on items without proof-of-purchase will be determined from the type of sale and manufacturing date code. Freight must be prepaid; items sent freight-collect, or COD, will be refused.

WHAT IS NOT COVERED?

This warranty is valid only if the product is used for the purpose for which it was designed. It does not cover:

- o Damage due to improper installation
- o Subsequent damage to other components
- o Damage caused by exposure to moisture, excessive heat, chemical cleaners, and/or UV radiation
- o Damage through negligence, misuse, accident or abuse. Repeated returns for the same damage may be considered abuse
- o Any cost or expense related to the removal or reinstallation of product
- o Speakers damaged due to amplifier clipping or distortion
- o Items previously repaired or modified by any unauthorized repair facility
- o Return shipping on non-defective items
- o Products with tampered or missing barcode labels
- o Products with tampered or missing serial numbers
- o Products returned without a Return Merchandise Authorization (RMA) number
- o Products purchased from an UNAUTHORIZED dealer
- o Freight Damage
- o The cost of shipping product to KICKER
- o Service performed by anyone other than KICKER

HOW LONG WILL IT TAKE?

KICKER strives to maintain a goal of one-week service for all acoustics (subwoofers, midrange drivers, tweeters, crossovers, etc) returns. Delays may be incurred if lack of replacement inventory or parts is encountered. Failure to follow these steps may void your warranty. Any questions can be directed to the KICKER Customer Service Department at (405) 624-8510. Contact your International KICKER dealer or distributor concerning specific procedures for your country’s warranty policies.

Garantía | Garantie

Contact your International KICKER dealer or distributor concerning specific procedures for your country's warranty policies.

Our goods come with guarantees that cannot be excluded under the **Australian Consumer Law**. You are entitled to a replacement or refund for a major failure and for compensation for any other reasonably foreseeable loss or damage. You are also entitled to have the goods repaired or replaced if the goods fail to be of acceptable quality and the failure does not amount to a major failure.

GARANTÍA INTERNACIONAL **Versión Español**

Comuníquese con su concesionario o distribuidor KICKER internacional para obtener información sobre procedimientos específicos relacionados con las normas de garantía de su país.

La frase “combustible para vivir la vida Livin’ Loud™ a todo volumen” se refiere al entusiasmo por la vida que la marca KICKER de estéreos de automóvil representa y a la recomendación a nuestros clientes de que vivan lo mejor posible (“a todo volumen”) en todo sentido. La línea de altavoces y amplificadores KICKER es la mejor del mercado de audio de automóviles y por lo tanto representa el “combustible” para vivir a todo volumen en el área de “estéreos de automóvil” de la vida de nuestros clientes. Recomendamos a todos nuestros clientes que obedezcan todas las reglas y reglamentos locales sobre ruido en cuanto a los niveles legales y apropiados de audición fuera del vehículo.

INTERNATIONALE GARANTIE **Deutsche Version**

Nehmen Sie mit Ihren internationalen KICKER-Fachhändler oder Vertrieb Kontakt auf, um Details über die Garantieleistungen in Ihrem Land zu erfahren.

Der Slogan “Treibstoff für Livin’ Loud” bezieht sich auf die mit den KICKER-Autostereosystemen assoziierte Lebensfreude und die Tatsache, dass wir unsere Kunden ermutigen, in allen Aspekten ihres Lebens nach dem Besten (“Livin’ Loud”) zu streben. Die Lautsprecher und Verstärker von KICKER sind auf dem Markt für Auto-Soundsysteme führend und stellen somit den “Treibstoff” für das Autostereoerlebnis unserer Kunden dar. Wir empfehlen allen unseren Kunden, sich bezüglich der zugelassenen und passenden Lautstärkepegel außerhalb des Autos an die örtlichen Lärmvorschriften zu halten.

GARANTIE INTERNATIONALE **Version Française**

Pour connaître les procédures propres à la politique de garantie de votre pays, contactez votre revendeur ou distributeur International KICKER.

L’expression “ carburant pour vivre plein pot “ fait référence au dynamisme de la marque KICKER d’équipements audio pour véhicules et a pour but d’encourager nos clients à faire le maximum (“ vivre plein pot “) dans tous les aspects de leur vie. Les haut-parleurs et amplificateurs KICKER sont les meilleurs dans le domaine des équipements audio et représentent donc pour nos client le “ carburant pour vivre plein pot “ dans l’aspect “ installation audio de véhicule “ de leur vie. Nous encourageons tous nos clients à respecter toutes les lois et réglementations locales relatives aux niveaux sonores acceptables à l’extérieur des véhicules.

P.O. Box 459

Stillwater, Oklahoma 74076

USA

(405) 624-8510

 **stillwaterdesigns**